

# A Fully Wheelchair Accessible Telescope for the Frank N. Bash Visitors Center

Authors: F. Cianciolo, W. Wren, M. Jones, W. Rosing



The WAT site below the research domes on Mt. Locke



The WAT site at the Visitors Center Telescope Park ready for installation

The McDonald Observatory hosts approximately 30,000 visitors each year at the Visitors Center's popular Star Party programs. An increasing percentage of these guests are mobility impaired or completely wheelchair bound. Such physical challenges can make it nearly impossible for these visitors to comfortably look through traditionally designed telescopes. The new Wheelchair Accessible Telescope (WAT) will soon be installed at the Visitors Center's Telescope Park that will address this need.

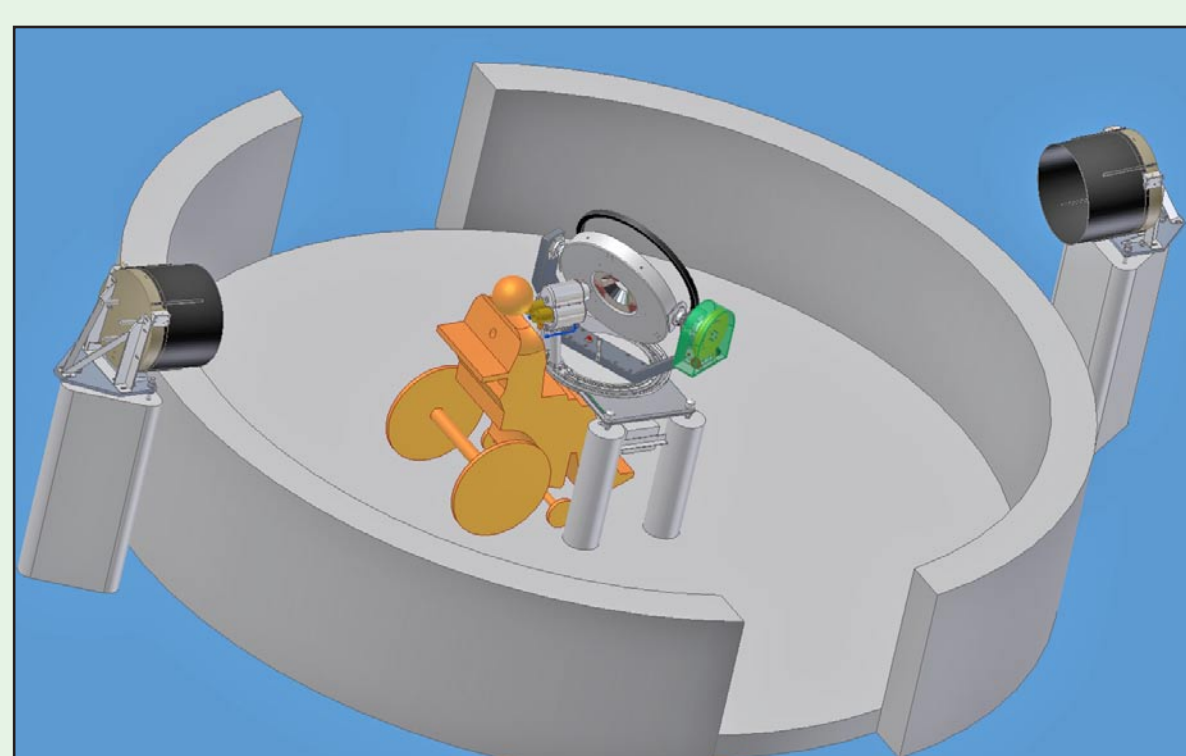

The Wheelchair Accessible Telescope system

Essentially a fixed focal point Pfund design ([http://en.wikipedia.org/wiki/Pfund\\_telescope](http://en.wikipedia.org/wiki/Pfund_telescope)), the original incarnation of the telescope at McDonald Observatory used to search visually for supernovae was inspired directly from a design independently developed by John Fundingsland dubbed the "Fundyscope" (Sky & Telescope 1992, 84, 212.) The modified design now includes two 18" (0.46m) primary mirrors aligned north-south with the steering flat mirror centered between them to allow easier, quicker access to the entire sky. To view the southern quadrant, the flat mirror is pointed towards the south primary with the observer to the north behind the flat. To view the northern sky, only the flat mirror and eyepiece assembly need to be rotated 180° to face the north primary.

Additionally, the relatively small movable portion of the design will allow the telescope to quickly slew to numerous targets in rapid succession while the eyepiece stays fixed. For those visitors who find that they cannot view through the Center's more traditionally designed telescopes, this high speed pointing system will allow a far greater level of participation in the Star Party programs than is currently available.

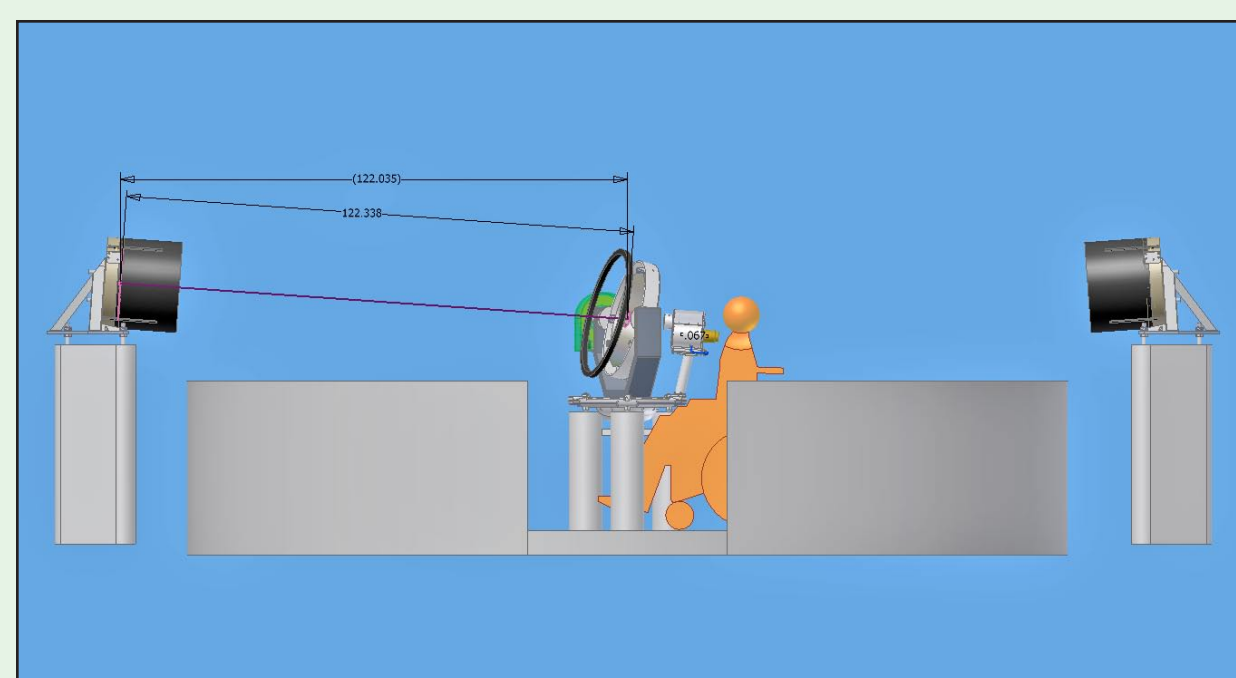

18" primary mirrors set north and south of the larger flat "steering" mirror

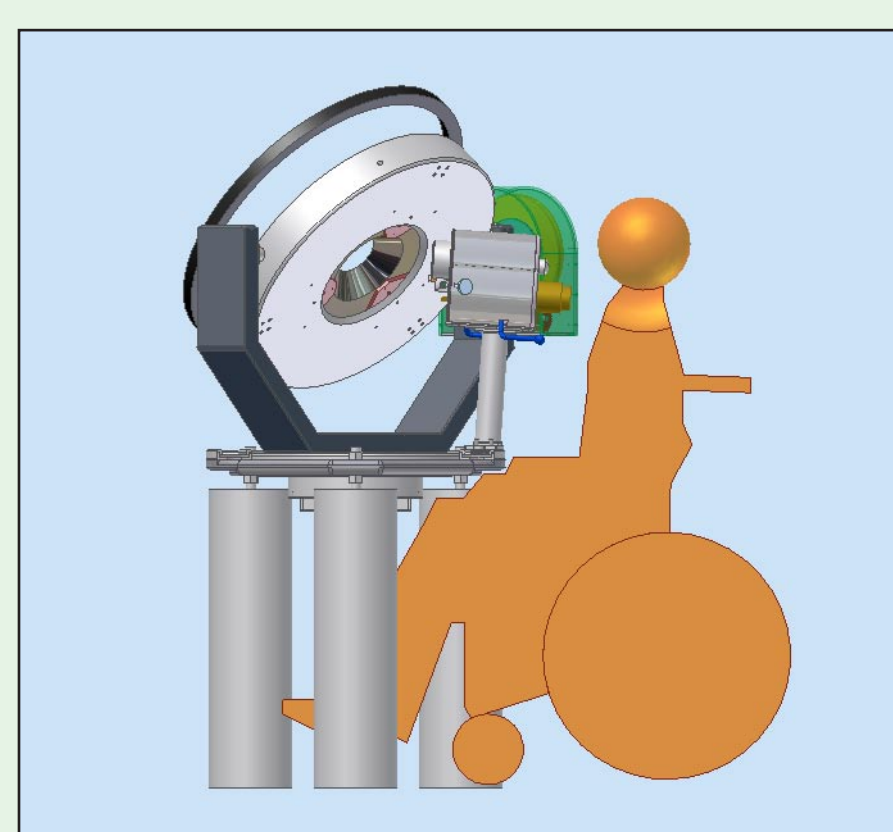

Wheelchair-bound visitors access the telescope simply by rolling up to the eyepiece

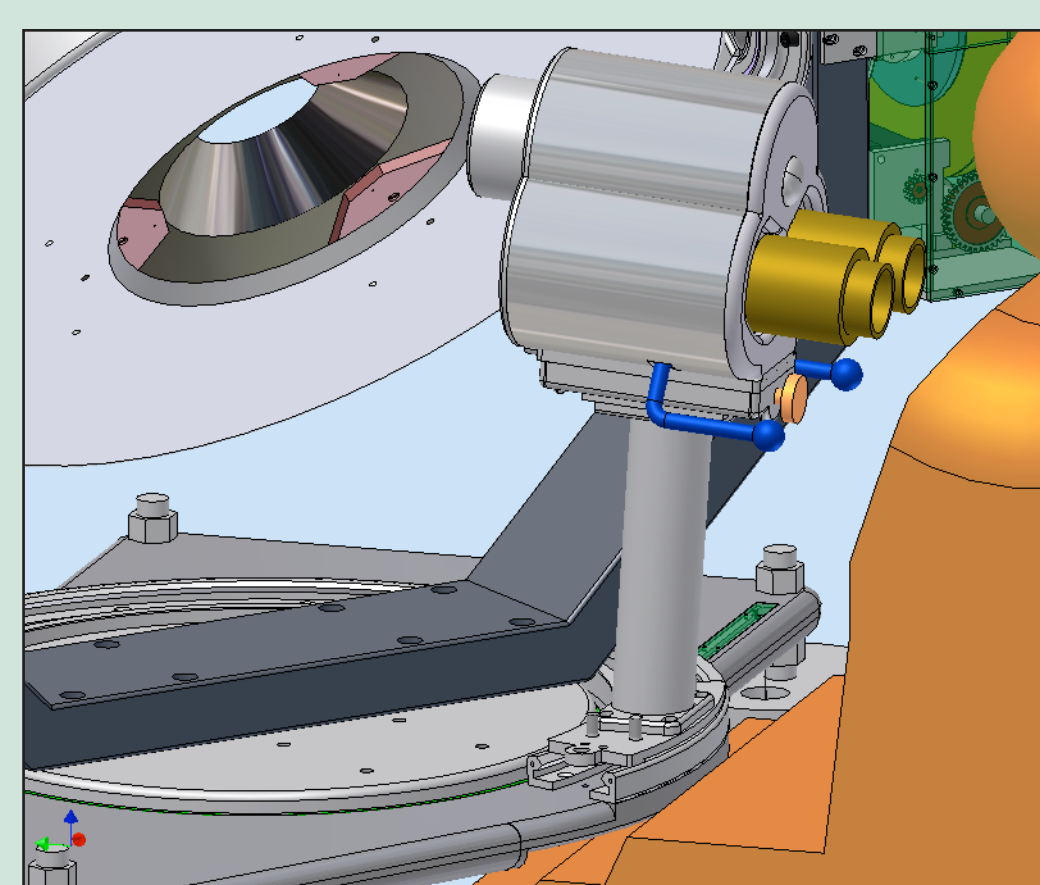

Binocular viewer behind steering flat

Thanks to the design and fabrication skills of the WAT team, the system will include several viewing options. A binocular viewer with quickly and easily adjustable intraocular separation was designed specifically to take full advantage of the unique imaging capabilities of the system.

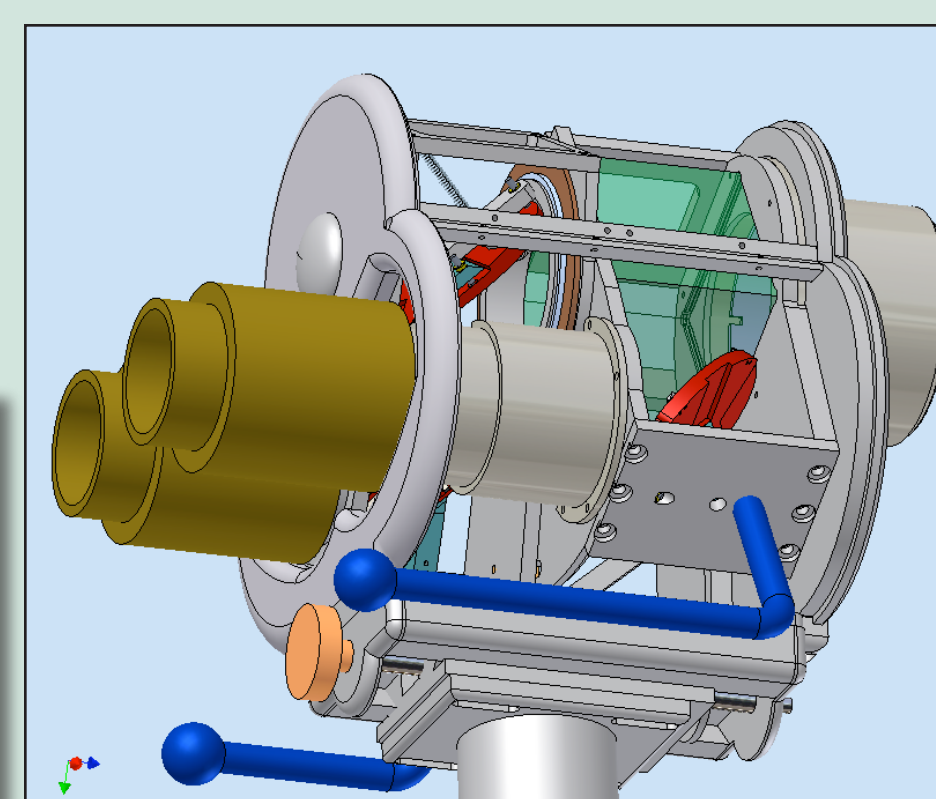

Intraocular space adjusts with two easily accessible handles



The binocular viewer housing ready for optics and final assembly

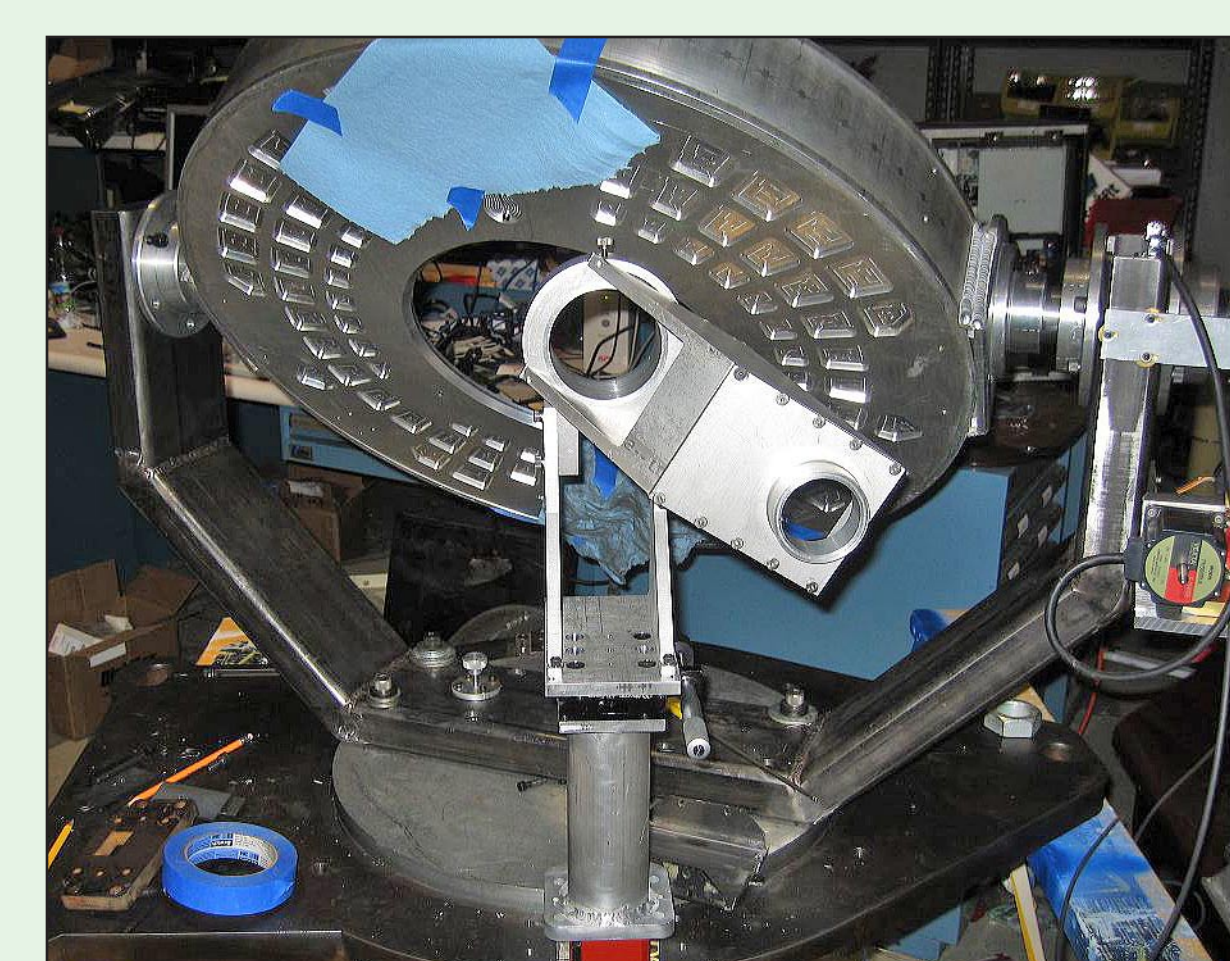

The adjustable periscope viewer awaiting optics

For larger crowds when minimizing the time needed to make adjustments is crucial, a straight-through viewing monocular system can be equipped with a standard diagonal for 2" eyepieces.

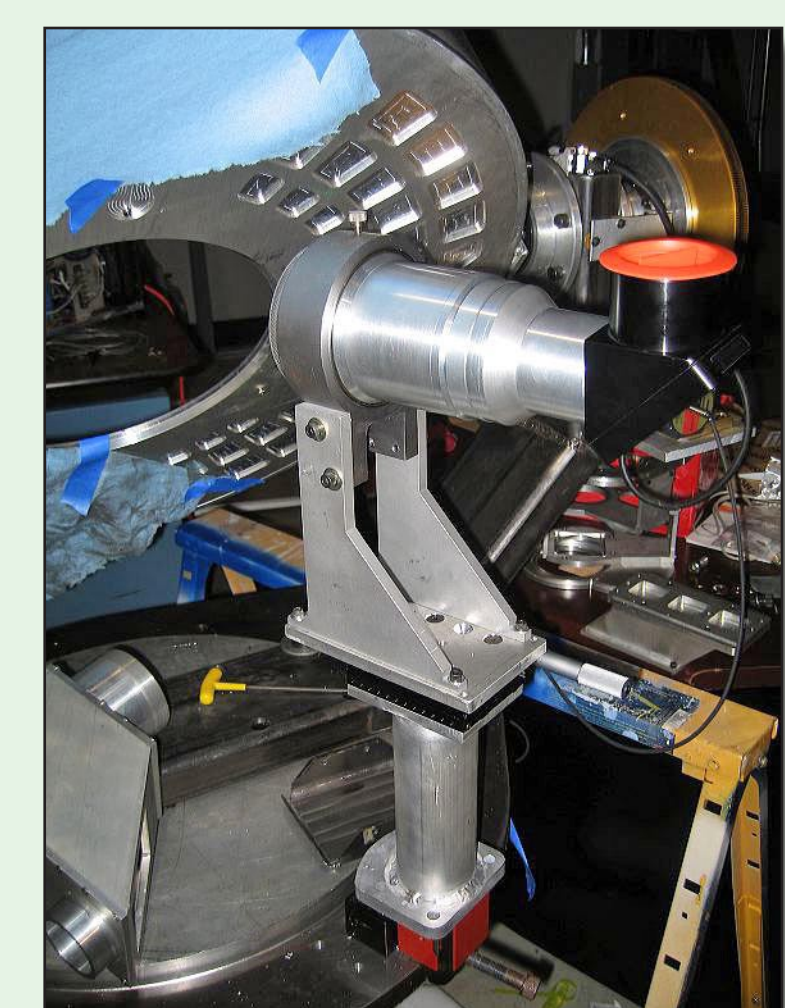

Straight-through monocular with 2" diagonal

Since the system is, by necessity of design, completely open, a site for the telescope was chosen to minimize interference from any potential light source and to allow for construction of ADA compliant paths. The site (top) has been prepared and awaits installation in late 2007 of the system now in final fabrication and assembly at Los Cumbres Observatory. (<http://lcogt.net/telescopes/snst2>)

For more information about the history and design of the Wheelchair Accessible Telescope, go to

<http://idisk.mac.com/rwren/Public/wmwat2/index.htm>

Alternately, to ensure that all wheelchair-bound visitors no matter what their seated height or degree of mobility can look through the telescope, an adjustable "periscope" viewer can be installed in place of the binocular system.

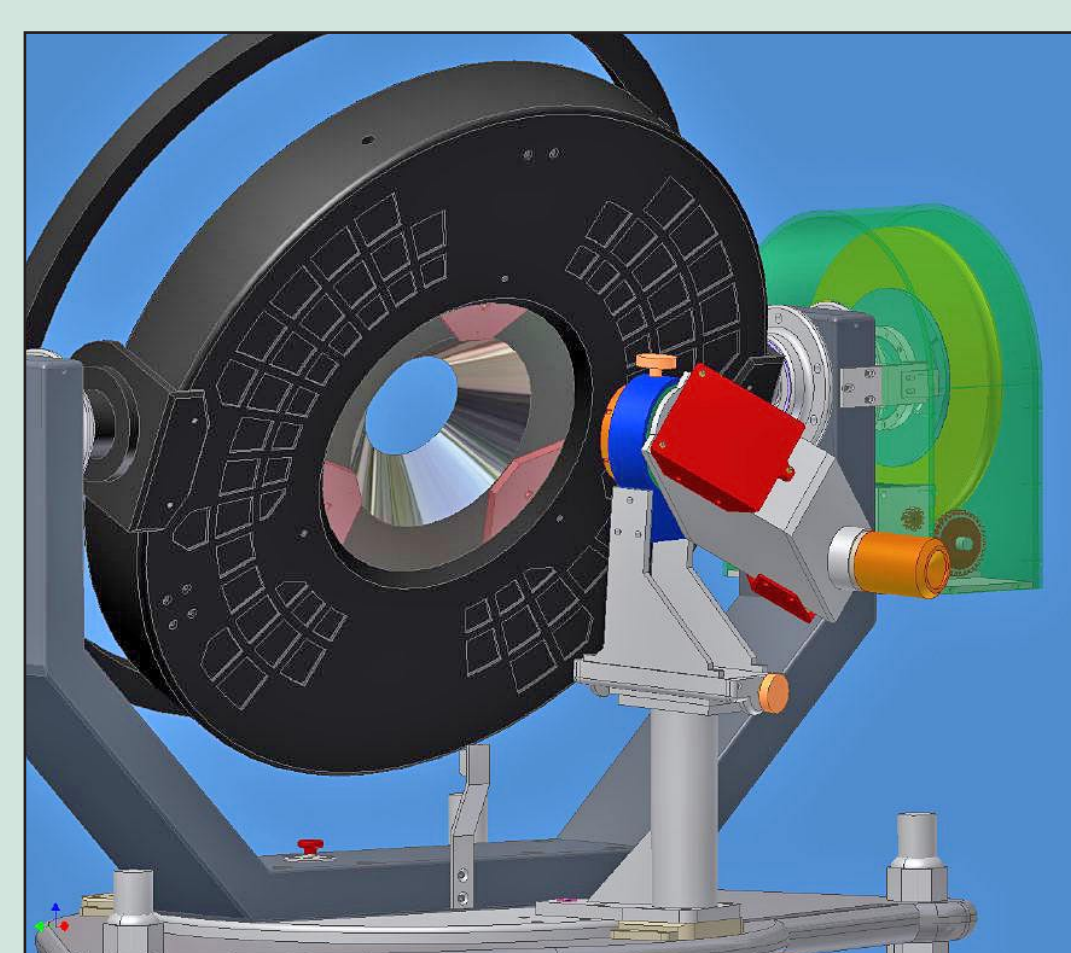

Continuously adjustable periscope viewer rotates about primary optical axis