

The wide field upgrade for the Hobby-Eberly Telescope

John A. Booth*^a, Phillip J. MacQueen^a, John M. Good^a, Gordon L. Wesley^a, Gary J. Hill^a, Povilas Palunas^a, Pedro R. Segura^a, Robert E. Calder^a

^aMcDonald Observatory, University of Texas at Austin, 1 University Station C1402, Austin, TX 78712-0259, USA

ABSTRACT

A major performance upgrade for the Hobby-Eberly Telescope (HET) is in the conceptual design phase. The extensive upgrade will include a wide field optical corrector, a new HET tracker with increased payload capacity, and improved telescope pointing and tracking accuracy. The improvements will support the HET Dark Energy Experiment (HETDEX), which seeks to characterize the evolution of dark energy by mapping the imprint of baryonic oscillations on the large scale structure of the Universe. HETDEX will use the increased field-of-view and payload to feed an array of approximately 145 fiber-fed spectrometers, called VIRUS for "Visible Integral field Replicable Unit Spectrograph".

The new corrector will have a science field-of-view diameter of 18 arcminutes, in contrast to the original corrector's 4 arcminute field, a twenty-fold increase in area. A new HET tracker with increased payload capacity will be designed to support the wide field corrector. Improved pointing and tracking will be accomplished using new autocollimation and distance measuring metrology combined with real-time wavefront sensing and correction. The upgrade will maintain operation of the current suite of facility instruments, consisting of low, medium, and high resolution spectrometers.

Keywords: Hobby-Eberly Telescope, HET, Dark Energy, HETDEX, VIRUS, integral field unit, spherical aberration corrector, mirror alignment, wavefront sensor, star tracking, autocollimator

1. INTRODUCTION

1.1. Wide Field Upgrade

The HET will undergo a major upgrade over the next 4 years as it is modified to support the HET Dark Energy Experiment (HETDEX), current, and future instrumentation. HETDEX is a project that encompasses both a Wide Field Upgrade (WFU) and an instrument called VIRUS, for "Visible Integral field Replicable Unit Spectrograph". HETDEX science and the VIRUS instrument are described elsewhere¹²³. The subject of this paper is the WFU. The upgrades consists of four related subprojects:

- The Wide Field Corrector (WFC)
- The new Prime Focus Instrument Package (PFIP)
- The new Tracker
- Modifications to the HET facility

The WFC, described in Section 4, will have an 18 arcminute diameter science field-of-view, with an additional field diameter of 22 arcminutes for field acquisition and guiding. It is similar to a design developed by the Southern African Large Telescope (SALT)⁴⁵, but almost twice as large in physical diameter. The field-of-view of the current HET corrector is about 4 arcminutes by comparison.

The new Prime Focus Instrument Package (PFIP), described in Section 5, serves as a mount and interface between the WFC and the new Tracker. The PFIP also supports a number of other critical telescope subsystems, among them the acquisition, guiding, and wavefront sensing probes and cameras, a moving pupil baffle, and an atmospheric dispersion

*booth@astro.as.utexas.edu, phone 512/471-3416

compensator. The PFIP also supports the integral field unit (IFU)⁶ for the VIRUS instrument. The IFU is an array of 145 fiber bundle inputs in the focal plane.

The new Tracker, described in Section 6, will replace the original tracker at the top end of the telescope structure. A new tracker is needed to support the much larger size and weight of the new corrector and PFIP.

Many facility modifications and additions will be made to support this project. The major modifications, some of which are described in Section 7, are: 1) telescope structure modifications to stiffen and support the additional payload weight, 2) additional azimuth air bearings, 3) a new VIRUS laboratory work area, and 4) a new telescope control hardware and software environment.

The Wide Field Upgrade project is to be completed in time to support the integration of the VIRUS instrument into the HET in late 2009.

2. Current status of HET

The HET is operating close to its original specifications, and in many areas, such as mirror alignment hold time, it significantly exceeds specifications. One important performance exception has been the delivered image quality. While much improved over recent years, over the past 12 months the HET has delivered a median image quality of 1.6 arcseconds full width at half maximum intensity (FWHM) in 1.1 arcsecond FWHM site seeing measured by a differential image motion monitor (DIMM). We expect the delivered image quality to approach the site seeing when the Tracker Metrology System (TMS) described below is fully implemented and operational later this summer⁷.

The TMS consists of a absolute distance measuring interferometer (DMI) and an autocollimator called the tip tilt camera (TTCAM). Errors in the positioning of the SAC have been found to be a major contributor to degraded image quality. The TMS provides direct metrology for the positioning of the SAC with respect to the primary mirror array.

Additional improvements have been made in the control of the primary mirror array. Improvements in the mirror segment edge sensor calibration and feedback loop have led to an improvement of 80% in stability performance in the past 9 months. The improved control system has provided higher bandwidth and reliability in control of the primary mirror.

A DMI was also incorporated in the mirror alignment system used for aligning the primary mirror, and has led to substantially better control of the primary mirror global radius of curvature, as well as to more efficient telescope operation.

Improvements in the setup of mirror segment mounts have yielded more consistent segment figure. Segment image analysis shows that the average current figure of the individual segments is now within specification, yielding images sizes of 0.4" EE50. Some low order figure errors remain, largely astigmatism, in many segments.

Extensive work on the telescope software and hardware controls over the past two years has resulted in a much more reliable telescope operating environment. Routine nighttime operation over 95% of the time with occasional minor problems are now the rule rather than the exception, which was not the case in the early years of operation.



Figure 1: The Hobby-Eberly Telescope facility

3. BACKGROUND

3.1. HET Description and History

The HET was funded and built by a consortium of five universities, the University of Texas at Austin, the Pennsylvania State University, the Ludwig-Maximilians Universität München, the Georg-August-Universität Göttingen, and Stanford University. Descriptions of the telescope⁸, its operation⁹, scientific instrumentation^{10,11,12,13}, commissioning experience^{14,15}, and early science results^{16,17} may be found at the indicated references, but a brief description of its operation and history is included here for the reader's convenience.

The fixed-elevation telescope employs a spherical segmented primary mirror supported by a steel truss as an essential part of the telescope's low-cost, Arecibo-style design concept. All 91 segments are identical regular hexagons. The unique design of the HET allows the primary mirror to remain stationary during an observation; it can be repositioned in azimuth between observations to access different areas of the sky. The mirror has a constant zenith angle of 35 degrees, and thus always has the same orientation with respect to gravity. Images of astronomical objects are acquired and followed across the mirror array at prime focus for up to 2.5 hours by means of a tracking device mounted atop the telescope structure. This unusual mode of operation is somewhat difficult to visualize, and the reader is referred to Figures 2 and 3, below, for a more visual description.

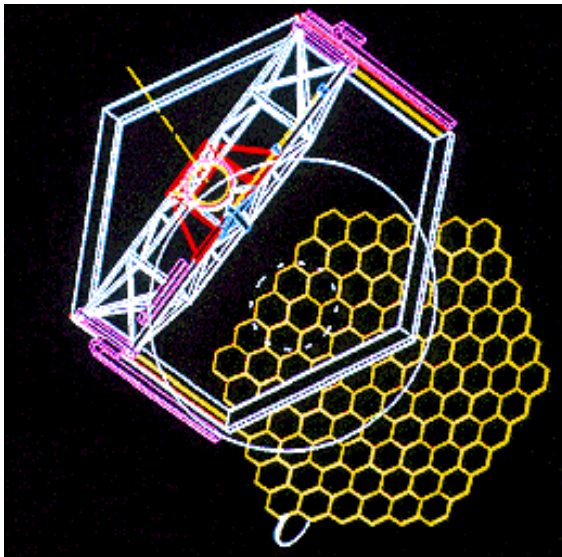

Figure 2: Telescope operation. (Tracker payload and telescope structure are not shown for clarity.) The telescope is pointing south and acquiring an object in the east. Note the large circle on the primary mirror, delineating the telescope entrance pupil on the primary.

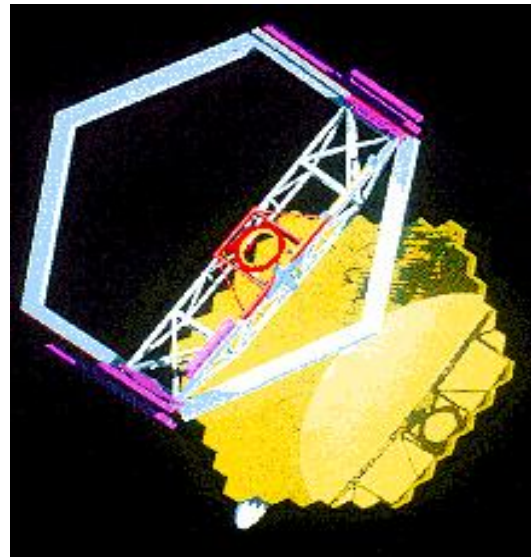

Figure 3: Telescope has completed track begun in Figure 2. Note the illuminated active pupil on the primary mirror. Object is now well past the meridian in the west.

The design simplifies the mirror support problem and significantly reduces the initial cost of the telescope. The construction cost of the telescope was \$13.9 M, about 15% of the cost of fully steerable telescopes of comparable size. Design and construction time was approximately five years. HET first light was achieved in December 1996 with seven mirror segments collecting and focusing light through a test optical corrector. Installation of the design corrector (February 1999) and first facility instrument, the Low Resolution Spectrograph (LRS), (April 1999) were followed by completion of primary mirror segment installation in May 1999. HET currently is in science operations over 96% of the time, with the remaining time used for engineering and instrument commissioning activities. We estimate that the total cost of the telescope, including instruments and commissioning, is about \$24M.

4. WIDE FIELD CORRECTOR (WFC)

4.1. Description

The baseline design for the WFC is a four-mirror design with two concave 1 meter diameter mirrors, one concave 0.9 meter diameter mirror, and one convex 0.23 m diameter mirror. Three of the mirrors are conic sections, and one is an 8th order polynomial aspheric. The corrector is designed for feeding optical fibers, and so the chief ray from all field angles is normal to the focal surface. This is achieved with a concave spherical focal surface centered on the exit pupil. The primary mirror spherical aberration and the off-axis aberrations in the wide field are controllable due to the first two mirrors being near pupils, and the second two mirrors being well separated from pupils. The aberration balance in the baseline design favors image quality in the outer field over on-axis performance. This is because most of the field area is in the outer field, and also for the following reason: The segmented primary mirror of the HET is not phased, and so the diffraction-based performance of the HET is determined by its 1 m diameter primary mirror segments. Therefore the on-axis performance of the baseline design need only be constrained to be comparable to the diffraction limit of a single primary mirror segment.

The $f/3.65$ corrector produces an unvignetted science field-of-view 18 arcminutes in diameter using a 10 m aperture, with a guiding and wavefront sensing annular field out to 22 arcminutes in diameter. The optical layout of the new corrector is shown below with both on-axis and full field ray traces. The spot diagrams that follow show the optical performance of the baseline design.

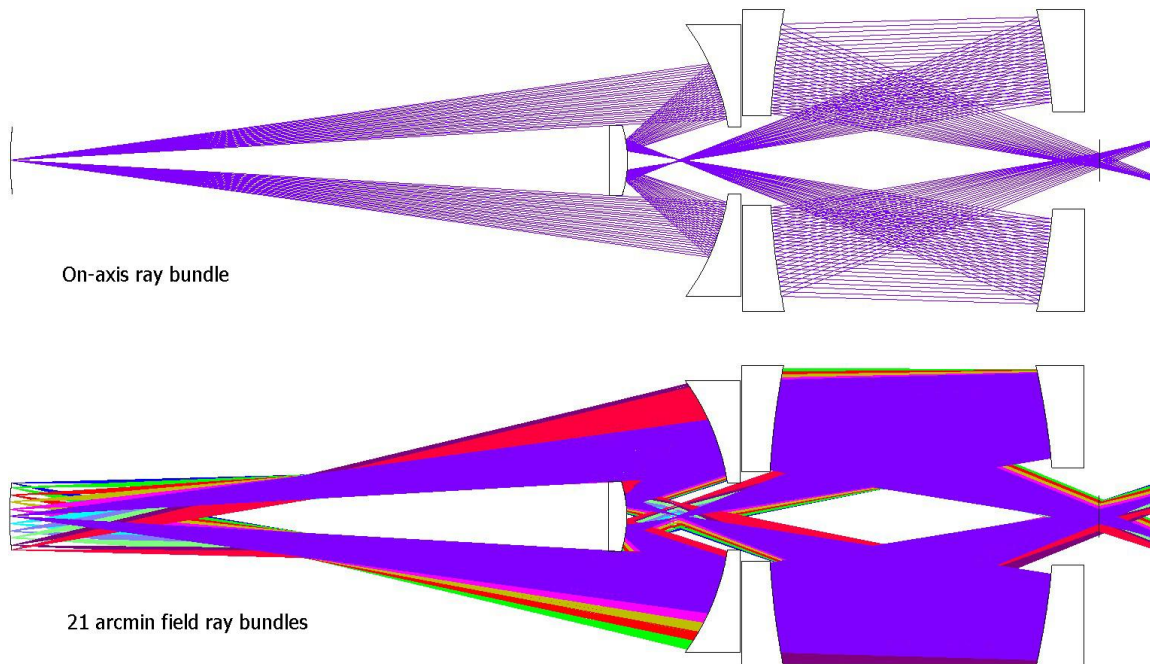

Figure 4: The baseline WFC optical configuration. The spherical primary mirror is not shown, being 12.896 m to the right of the corrector and concave toward the corrector. The two largest mirrors have 1 m diameters, and the separation between the primary mirror prime focus (circle of least confusion) and focal surface is 3.646 m. The exit pupil is 0.995 m before the focal surface.

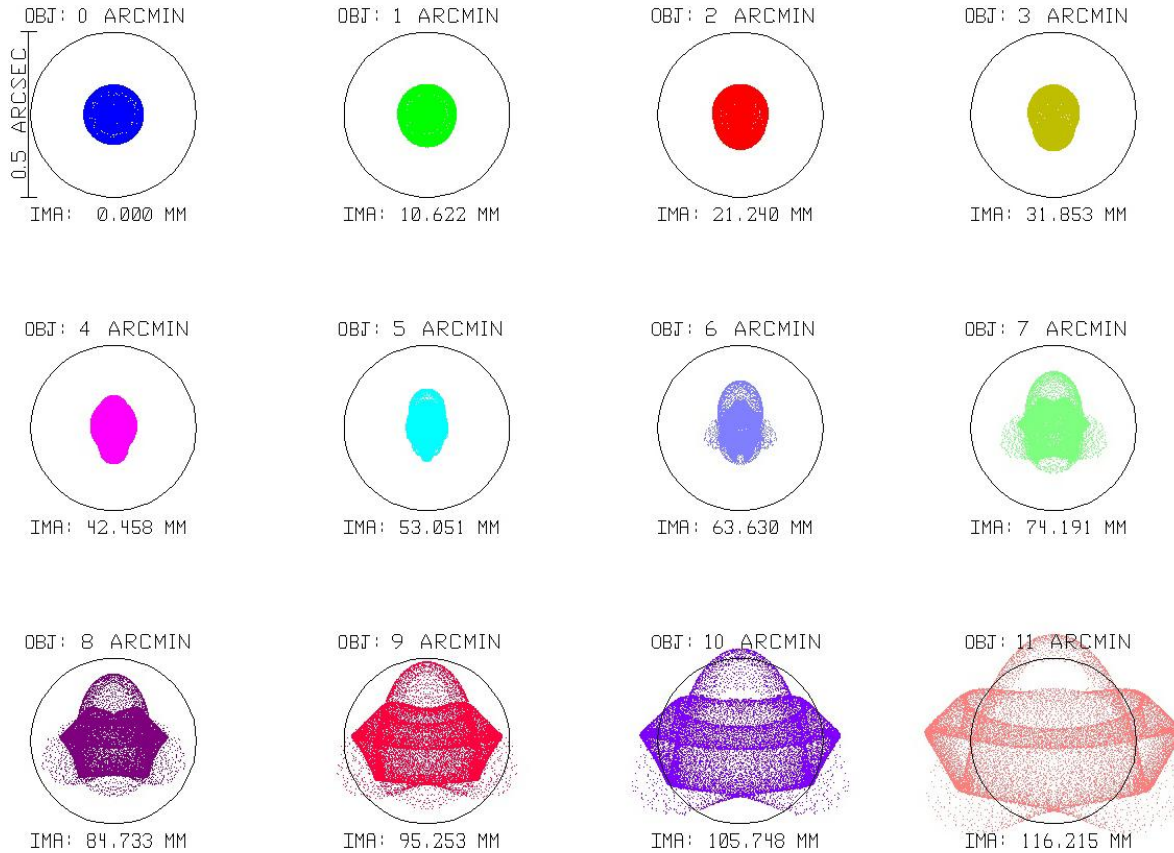

Figure 5: Spot diagrams showing the imaging performance of the baseline WFC design at focus. The reference circle is 0.5 arcseconds in diameter.

4.2. Design and Cost Study

A design and cost study of the WFC is currently being solicited. The goal of the study is to develop a conceptual design for the WFC using the above optical design as a baseline. The specific tasks to be accomplished by the study contractor include:

1. Perform an optical analysis of the provided WFC optical design
2. Develop preliminary specifications for the optical elements
3. Determine manufacturability of the as-designed optical components
4. Develop a complete concept design for the WFC
5. Develop a comprehensive project plan and schedule
6. Determine the estimated cost to within 10%, including a cost breakdown

The study should be completed by September 2006, and will provide the basis for the specifications and requirements and procurement documents being developed to initiate the procurement of the WFC.

5. PRIME FOCUS INSTRUMENT PACKAGE (PFIP)

The current concept for the Prime Focus Instrument Platform (PFIP) calls for the corrector assembly to be a cylindrical-shaped, sealed unit that can be removed from the frame of the PFIP without disturbing the other systems on the frame. The corrector will be kinematically mounted and constrained to minimize stresses in the frame and maximize repeatability.

The PFIP frame will be a welded structure mounted in the carriage of the tracker. It has not been decided if the PFIP will rotate during an observation, but it will need the capacity to rotate for maintenance and access. A bearing set will permit the PFIP to rotate about the optical axis. The load path through the frame is designed to put the axial loads over the bearing instead of cantilevered from the bearing.

An Atmospheric Dispersion Compensator (ADC) is located just below the pupil and a moving aperture stop is located at the pupil to block stray light from around the primary mirror. Both are mounted to the PFIP frame.

Within the instrument rotator is a fold mirror to direct the beam to the low-resolution spectrograph and other secondary focal planes. Located at the prime corrected focus are the IFU and fiber head for VIRUS and other fiber-fed instruments. A shutter is located below the head, and fiber-fed guide probes are positioned just below the shutter.

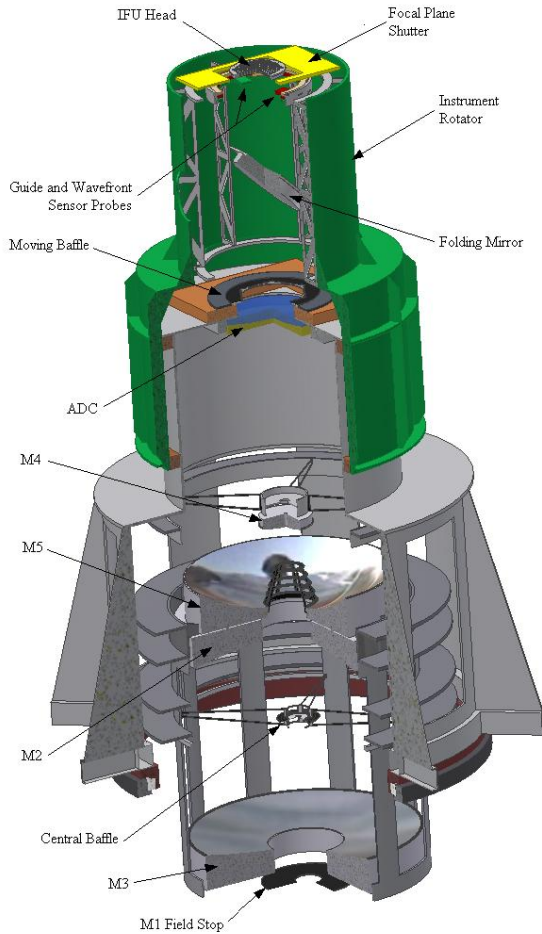

Figure 6: PFIP elements with WFC

While a key feature of VIRUS is to utilize a relatively simple, non-state-of-the-art spectrograph, camera, and detector, the fact remains that the typical stability, thermal and cryo-cooling requirements persist. Since there are 145 of them roughly 20 meters above convenient access and in close proximity to the primary optical pathway, the challenge of mounting, thermally isolating, cooling, maintaining and minimizing fiber length for the entire instrument, becomes a serious challenge that presents significant scientific, engineering, financial and management trades. While over a dozen concepts have been explored, they break down roughly into two categories which involve either mounting VIRUS on the tracker and within the central obscuration of the WFC, or mounting outside the field-of-view on the upper hexagon of the telescope structure. The requirement to maintain efficient throughput at 350 nm placed an upper limit on the fiber

6. TRACKER UPGRADE & VIRUS LOCATION

6.1. General

The upgrade of the HET tracker will essentially be a 3rd generation design, benefiting not only from lessons learned from the HET, but also from those of SALT which was a 2nd generation improvement over HET. The proposed corrector is approximately twice the size and mass of the present corrector, requiring the future tracker to be scaled in size and capacity to accommodate the forces and translation envelope of the new corrector. A number of VIRUS locations have been studied in detail and depending on the ultimate location selected, it has been demonstrated that a re-engineered tracker could support the entire VIRUS array, although a number of competing science, engineering, schedule and cost trades make this an unlikely choice. Regardless of VIRUS location, however, the tracker will need to accommodate the mass and forces imposed by over 35,000 fibers linking the focal surface of the WFC to each instrument in the VIRUS array. The unique design of the HET allows considerable flexibility in placing a large, heavy instrument at the top of the structure in proximity to the WFC focal surface, as long as fibers are used to decouple the precision motions of the corrector from the mass of the instrument itself. The challenge lies in obtaining sufficient throughput, which provides the motivation for positioning VIRUS as close as possible to the WFC focal surface.

6.2. Concept studies for location of VIRUS

length at 14 meters. The initial goal of the study was to substantially exceed this requirement by exploring the possibility of locating VIRUS on the tracker and within the 4.5 m central obscuration of the WFC. While throughput is excellent in this location, there are substantial risks encountered in this approach that motivate a serious exploration of alternative concepts which locate VIRUS outside the optical beam, but within the 14 m fiber length requirement. Ultimately, it can be argued that advantages in throughput can be sacrificed to an ultimate science gain, if the throughput loss is offset by simpler and less costly concepts that significantly shorten the time to actual collection of data because of reduced schedule consumed in fund-raising, engineering, fabrication, installation and commissioning.

6.2.1. VIRUS mounted on Tracker

Location of VIRUS on the tracker and within the central obscuration of the WFC requires a dense arrangement of VIRUS units in vertical modules of 12 to 14 units each. The modular sections assemble to create a cylinder

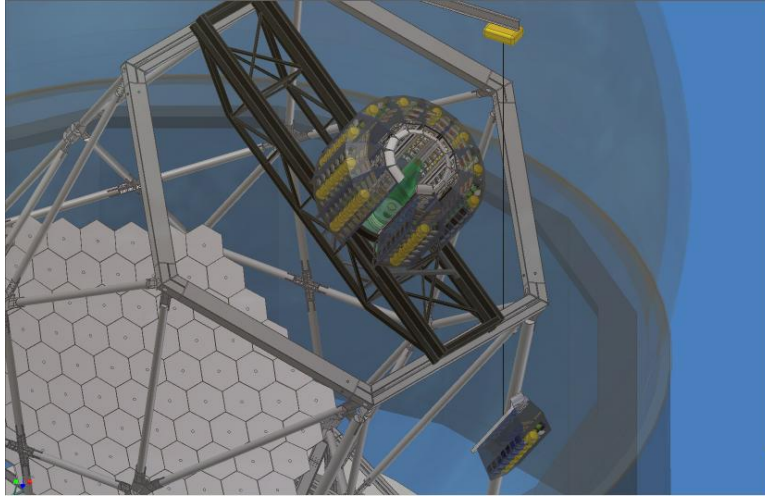

Figure 7: A concept of VIRUS mounted on the tracker within the central obscuration of the Wide Field Corrector. A 14 unit module is shown being lifted by the facility dome crane.

surrounding the WFC (Figure 7), and follow the focal surface as the WFC tracks the sky. The on-tracker concept study concludes that it is possible to arrange as many as 154 (one hundred fifty-four) VIRUS units within a circle of 4.1 meters while allowing a 2 meter diameter inner volume for the movement of the WFC. The payoff is realization of fiber lengths in the 2.5 to 4 meter range depending on the mounting of the WFC and tracking. However, numerous complexities accompany the gain in throughput. The increase in tracker payload, due only to VIRUS, is estimated at 12,100 kg. This prompted a study of the impact on the natural frequency of the tracker and structure. To expedite this process the existing tracker finite element analysis (FEA) model was rescaled and modified to give structural members additional cross-section. The resulting, un-

optimized tracker structure produced a fundamental mode at 4.3 Hz, and enhancements to the upper hexagon of the structure resulted in a first mode for the overall structure of 5.0 Hz. While it is clear that this structural performance can be improved upon with optimization, it is not apparent how sensitive the tracker structure will be to wind energy as a result of the increased sail area presented by the VIRUS enclosure. It has been demonstrated that wind energy near the dome aperture dominates airflow in the enclosure and exhibits behavior that is sometimes difficult to predict, thereby reducing the effectiveness of computer modeling to address this issue as a risk.

Other risks and complicating factors to this concept include:

- Lack of a stationary gravitational vector which complicates the mounting of optics and the handling of cryogenics
- Mount-model sensitivity to change in tracker payload due to the loss of cryogen during observation
- A limited envelope for movement of the WFC, as well as limitations to existing HET instrumentation that attach to the prime-focus
- Servicing and maintenance access

While these issues can be engineered to acceptable risk level, they present a cost, time, and resource burden on the project that may offset the significant, but single benefit, of greater fiber throughput.

6.2.2. VIRUS mounted on telescope upper hexagon

Mounting VIRUS on the upper hexagon and outside the optical beam allows a greatly simplified arrangement of the VIRUS array. The array is divided in to two 9 x 9 sectors. With the corners of each array removed this creates 145 VIRUS locations with an additional 9 spaces for alternate spectrograph configurations or spares. The proposed location of VIRUS on the upper hexagon (below, Figure 8) is based on a compromise between wind exposure from the dome aperture and fiber length. Thermal isolation is achieved by enclosing the arrays in insulated boxes, which contain heat exchangers to regulate the interior temperature. Each array is mounted vertically to simplify multiple aspects of the design including optical mounting, handling of cryogenics, and maintenance access.

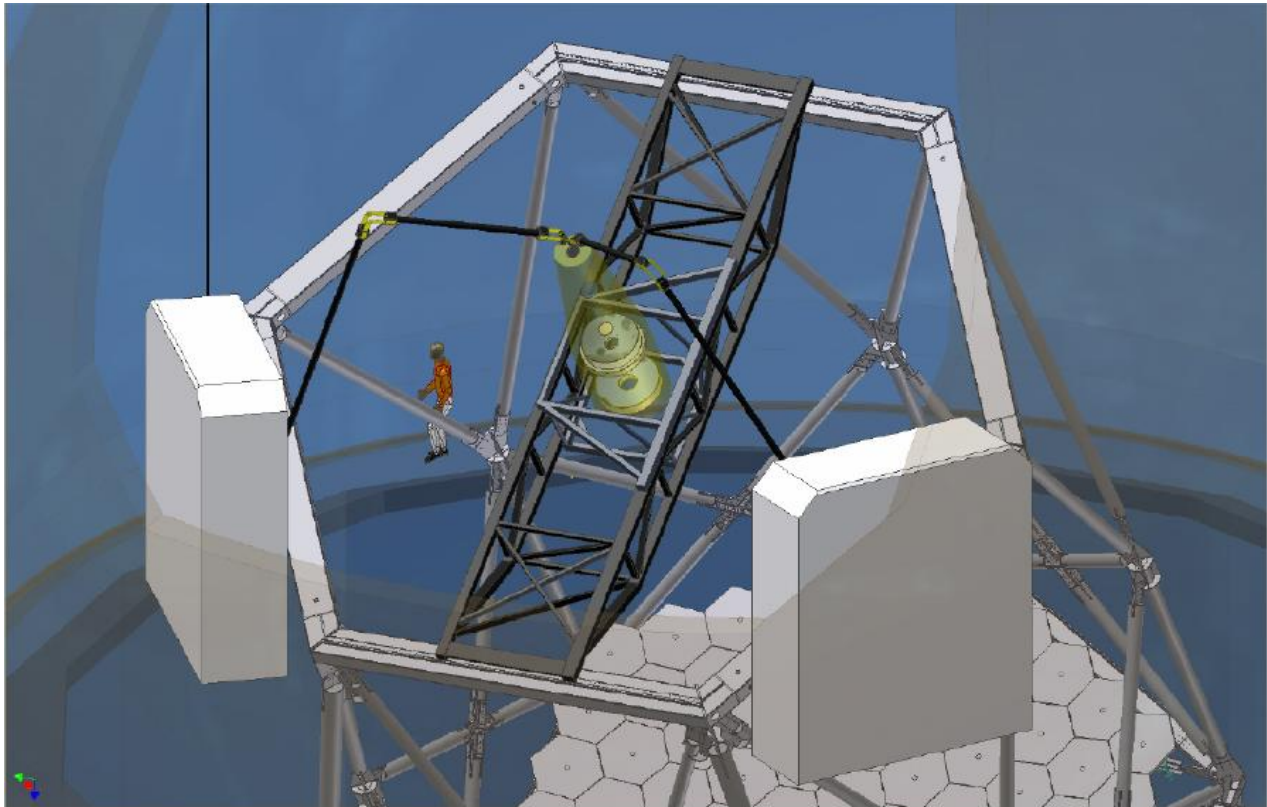

Figure 8: A concept of VIRUS mounted on the upper hexagon of the HET telescope structure. The white rectangular boxes can contain up to 154 spectrometers (77 each). Fiber handling from the WFC to each enclosure is by hinged carriers.

Benefits of this approach include:

- Support of the instrument mass on a substantially stiffer structure that results in less requirement to light-weight components, with corresponding cost savings
- Simplified array and optical mounting structure with stationary gravity vector resulting in less complicated components, with corresponding cost savings
- Easier, more cost-effective control of thermal envelope resulting in better dome seeing and lower cost
- Less complicated cryo-cooling design and maintenance, and minimal system sensitivity to changes in mass as cryogenics are lost
- Improved maintenance access
- Reduced risk to overall project schedule

Disadvantages include:

- Maximum allowed fiber length (14 m)
- Much more complex fiber handling (Section 6.3)
- Fiber wind loading

6.3. Concept Studies for Fiber Feed to VIRUS

In the baseline design, VIRUS is fed by 145 fiber bundles of 246 fibers each, for a total of 35,670 fibers. Considering these numbers and the technical challenges, fiber handling could be considered a valid project entity unto itself. However, the intricate role it plays with the tracker design and its ultimate performance requires that they be married to

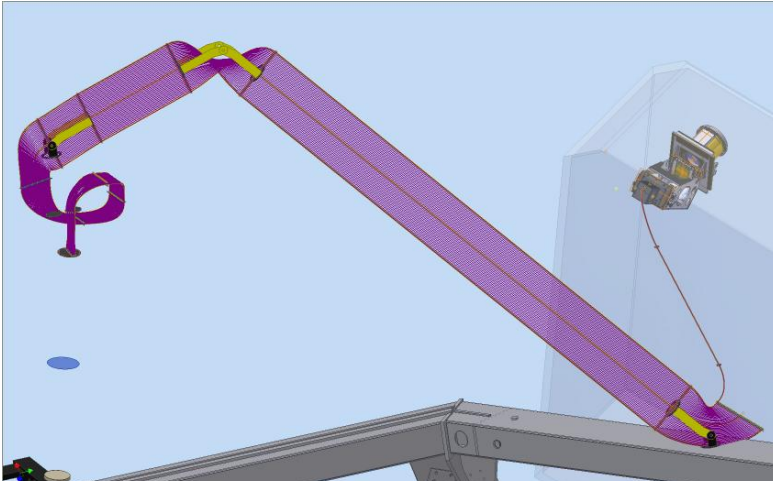

Figure 9: 73 fiber bundles, each carrying 246 fibers must translate through multiple degrees of freedom from the focal surface of the WFC shown at right to each VIRUS unit, one of which is shown to the left within one of the two VIRUS enclosures.

assure they work as a single unit. The most challenging design is driven when VIRUS is positioned on the upper hexagon of the telescope structure. Focal Ration Degradation concerns dictate that the minimum fiber bend radius be 150 mm. The fibers must be allowed to translate freely through the 6 axes of motion of the WFC and end at a stationary VIRUS array through the shortest possible distance. Deciding which degrees of freedom to control and which to leave free for the fiber to determine on its own poses a challenging problem and is key to the success of the entire telescope system. The problem is further complicated by wind loading, which is strongest in this region of the enclosure, and the desire to reduce obscuration of the optical beam. While many details remain to be solved, the most promising concept to date is to arrange the fiber bundles as if they were a giant ribbon cable, as illustrated in Figure 9.

A large loop, starting at the focal surface and anchored on the tracker carriage is proposed in order to absorb the complex motions of the WFC focal surface. From the carriage anchor point to the entrance of the VIRUS array enclosure, the necessary bending joints are handled by folding the “ribbon” to create a joint so each fiber bundle has the same bend radius about the joint and therefore are not required to lengthen as the bend angle changes. The narrow profile of the ribbon is oriented along the primary optical axis to minimize the shadow cast upon the primary mirror. The remaining problem of wind loading is mitigated by two approaches. The first is to create an optimum gap between individual bundles for air to pass through. The second approach is to reduce the overall width of the ribbon by using 2 or 3 ribbons, side by side, instead of a single wide ribbon.

7. FACILITY MODIFICATIONS

7.1. General

An array of modifications will need to be completed at the current HET site in order to prepare for the arrival and installation of the Wide Field Upgrade. The major modifications are: 1) telescope structure modifications to stiffen and support the additional payload weight, 2) additional azimuth air bearings, 3) a new VIRUS laboratory work area, and 4) a new telescope control hardware and software environment. The telescope modifications are described below.

7.2. Telescope structural modifications

The telescope structure was designed to handle the tracker and related payloads with a first mode frequency of 6 Hz. Figure 10 illustrates proposed modifications to the structure in order to support a heavier tracker and WFC payload, as well as an estimated VIRUS payload of 12,100 kg. As described in Section 6.2.1, FEA of the structure predicts a 1st mode of 5.0 Hz, which is comfortably above the normal wind power spectrum.

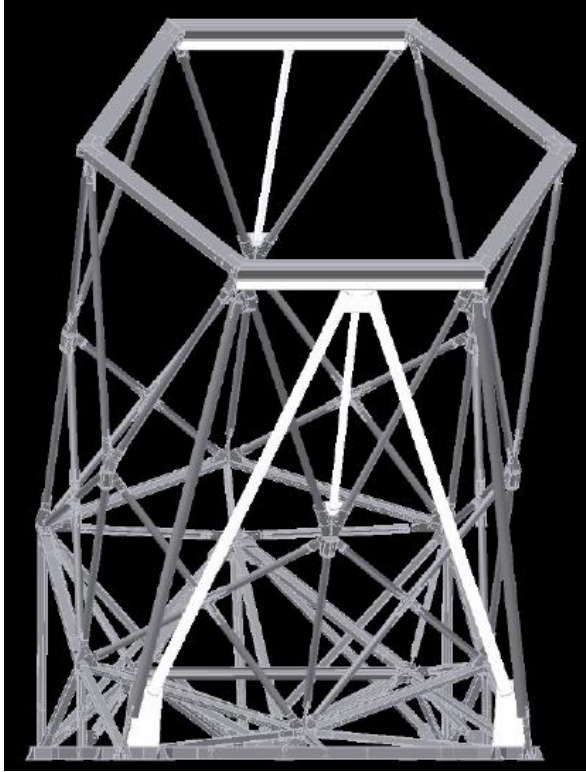

Figure 10: Concept-level modifications to the telescope structure (shown highlighted in white).

7.3. Additional air bearings

The telescope structure rotates in azimuth on eight 36-inch diameter air bearings, with pairs of bearings located at each of the four corners of the structure. There will be a need for additional air bearings similar to the ones currently used to levitate the telescope for azimuth moves, due to the increased weight of the rotating telescope assembly. The new air bearings may be located somewhat asymmetrically in azimuth to balance the loads of VIRUS and the larger tracker and payload.

7.4. Off-telescope shakedown of HETDEX

In order for HETDEX to be integrated and commissioned efficiently on the telescope with a minimum of down time, the entire system will be assembled and operated “on the ground” before final assembly on a test stand. This approach was used in the development of the original HET tracker at the contractor’s facility, and afforded many advantages.

8. PROJECT COST, FUNDING, AND TIMELINE

The cost for the entire HETDEX design and construction effort is estimated to be approximately \$33M. Some costs contributing to this estimate won’t be accurately known until the HETDEX Conceptual Design Review in the first half of

2007. The cost for the WFU project is roughly one half this total amount, including a contingency of 15%.

Funding for the project is in the form of grants, private contributions, and in-kind pledges from HET partners and other institutions. The total for contributions currently in hand, pledged, and anticipated is \$15.7M, or about half the total required for full funding. Efforts are underway to raise the remaining necessary funding.

We anticipate completing the conceptual design phase of HETDEX, culminating in the HETDEX CoDR, in the first half of 2007. Following a successful CoDR, long-lead contracts will be let for well-developed designs, and we will proceed with the remaining design and construction phases of the project. Integration of the various subsystems at the HET site is planned for fall 2009, followed by a commissioning phase to shake down and test the WFU and new VIRUS instrument in combination. Preliminary science observations for HETDEX could begin as early as December 2009.

9. SUMMARY

The HET will receive a major capability upgrade in a number of areas to support HETDEX. A new wide field corrector is being developed to provide an 18 arcminute science field-of-view for the telescope. A new acquisition and guiding system, wavefront sensor, atmospheric dispersion compensator, and moving baffle will be developed and incorporated into the new PFIP to accommodate the larger corrector and to improve telescope performance.

A new Tracker is being developed to support the increased load and volume of the combined WFC/PFIP payload. Improved pointing and tracking will be accomplished using new autocollimation and distance measuring metrology combined with real-time wavefront sensing and correction.

An array of approximately 145 fiber-fed spectrometers, called VIRUS, will be fiber-fed from the science field-of-view. The upgrade will maintain the functionality of the current suite of facility instruments, consisting of low, medium, and high resolution spectrometers.

10. REFERENCES

- ¹ G.J. Hill, P.J. MacQueen, J.R. Tufts, A. Kelz, M.M. Roth, W. Altmann, P.R. Segura, K. Gebhardt, P. Palunas, "VIRUS: a massively-replicated integral-field spectrograph for HET, Proc. SPIE **6269**, 93, 2006, in press
- ² G.J. Hill, P.J. MacQueen, C. Tejada, P.J. Cobos, P. Palunas, K. Gebhardt, & N. Drory, "VIRUS: a massively-replicated IFU spectrograph for HET," *Proc. SPIE*, **5492**, 25, 2004
- ³ G.J. Hill, & P.J. MacQueen, "VIRUS: an ultra cheap 1000-object IFU spectrograph", Proc. SPIE **4836**, 306, 2002
- ⁴ D. O'Donoghue, A. Swat, "The Spherical Aberration Corrector for the Southern African Large Telescope (SALT)", in Large Lenses and Prisms, Proc. SPIE **4411**, pp. 72-78, 2001.
- ⁵ D. O'Donoghue, "The correction of spherical aberration in the Southern African Large Telescope (SALT)", in Optical Design, Materials, Fabrication, and Maintenance, P. Dierickx, ed., Proc. SPIE **4003**, pp. 363-372, 2000.
- ⁶ A. Kelz, Prototype development of IFU for VIRUS, Proc. SPIE 6273, 151, 2006, in press
- ⁷ P. Palunas, P.J. MacQueen, J.A. Booth, R.E. Calder, J.R. Fowler, M.D. Shetrone, S.C. Odewahn, P.R. Segura, G.L. Wesley, G. Damm, J. Martin, P.S. Odoms, Imaging performance of the Hobby-Eberly Telescope, Proc. SPIE **6267**, 96, 2006, in press
- ⁸ L.W. Ramsey, M.T. Adams, T.G. Barnes, J.A. Booth, M.E. Cornell, J.R. Fowler, N.I. Gaffney, J.W. Glaspey, J. Good, P.W. Kelton, V.L. Krabbendam, L. Long, F.B. Ray, R.L. Ricklefs, J. Sage, T.A. Sebring, W.J. Spiesman, and M. Steiner, 1998, "The early performance and present status of the Hobby-Eberly Telescope," S.P.I.E. Vol. **3352**, Advanced Technology Optical/IR Telescope VI, p.34.
- ⁹ M. T. Adams, T. G. Barnes III, C. E. Nance and L. W. Ramsey, 2000, "Hobby-Eberly Telescope Operations Model", S.P.I.E. Vol. **4010**, *Observatory Operations To Optimize Scientific Return*.
- ¹⁰ Hill, G.J., H. Nicklas, P.J. MacQueen, C. Tejada de V., F.J. Cobos D., and W. Mitsch, 1998, "The Hobby-Eberly Telescope Low Resolution Spectrograph," S.P.I.E. Vol. **3355**, p. 375.
- ¹¹ G.J. Hill, P.J. MacQueen, C. Tejada de V., F.J. Cobos D., H. Nicklas, and W. Mitsch, 2000, "The Low Resolution Spectrograph of the Hobby-Eberly Telescope I. Description and Early Performance", P.A.S.P.
- ¹² R. G. Tull, 1998, "High-resolution fiber-coupled spectrograph of the Hobby-Eberly Telescope", S.P.I.E. Vol. **3355**, Part One, *Optical Astronomical Instrumentation*, p. 387.
- ¹³ S. D. Horner, L. G. Engel, L. W. Ramsey, 1998, "Hobby Eberly Telescope medium-resolution spectrograph and fiber instrument feed", S.P.I.E. Vol. **3355**, Part One, *Optical Astronomical Instrumentation*, p. 399.
- ¹⁴ T.G. Barnes III, M. T. Adams, J.A. Booth, M.E. Cornell, N. I. Gaffney, J. R. Fowler, G. J. Hill, C. E. Nance, L. W. Ramsey, R. L. Ricklefs, W. J. Spiesman, T. Worthington, 2000, "Commissioning Experience With The 9.2m Hobby Eberly Telescope", SPIE Vol. **4004**, Telescope Structures, Enclosures, Controls, Assembly/Integration/Validation, and Commissioning.
- ¹⁵ J.W. Glaspey, M.T. Adams, J.A. Booth, M.E. Cornell, J.R. Fowler, V.I. Krabbendam, L.W. Ramsey, F.B. Ray, R.L. Ricklefs, and W.J. Spiesman, 1998, "Hobby-Eberly Telescope: commissioning experience and observing plans," S.P.I.E. Vol. **3349**, *Observatory Operations to Optimize Scientific Return*, p.50.
- ¹⁶ G. J. Hill, P. J. MacQueen, L. W. Ramsey and E. L. Robinson, 2000, "Early Science Results from the Hobby-Eberly Telescope", S.P.I.E. Vol. **4005**, *Discoveries and Research Prospects from 8 - 10 Meter Class Telescopes*.
- ¹⁷ L. W. Ramsey et al., Early science and future prospects for the Hobby-Eberly telescope, SPIE vol. **4834**, *Discoveries and Research Prospects from 6 - 10 Meter Class Telescopes*, 2002