

Planet Detection

Estimating f_p

Can We See Them?

- Not easily
 - Best cases were reported in late 2008
- Problem is separating planet light from star light
 - Star is 10^9 times brighter in visible light
 - “Only” 10^6 times brighter in infrared

Planet is Much Fainter than Star

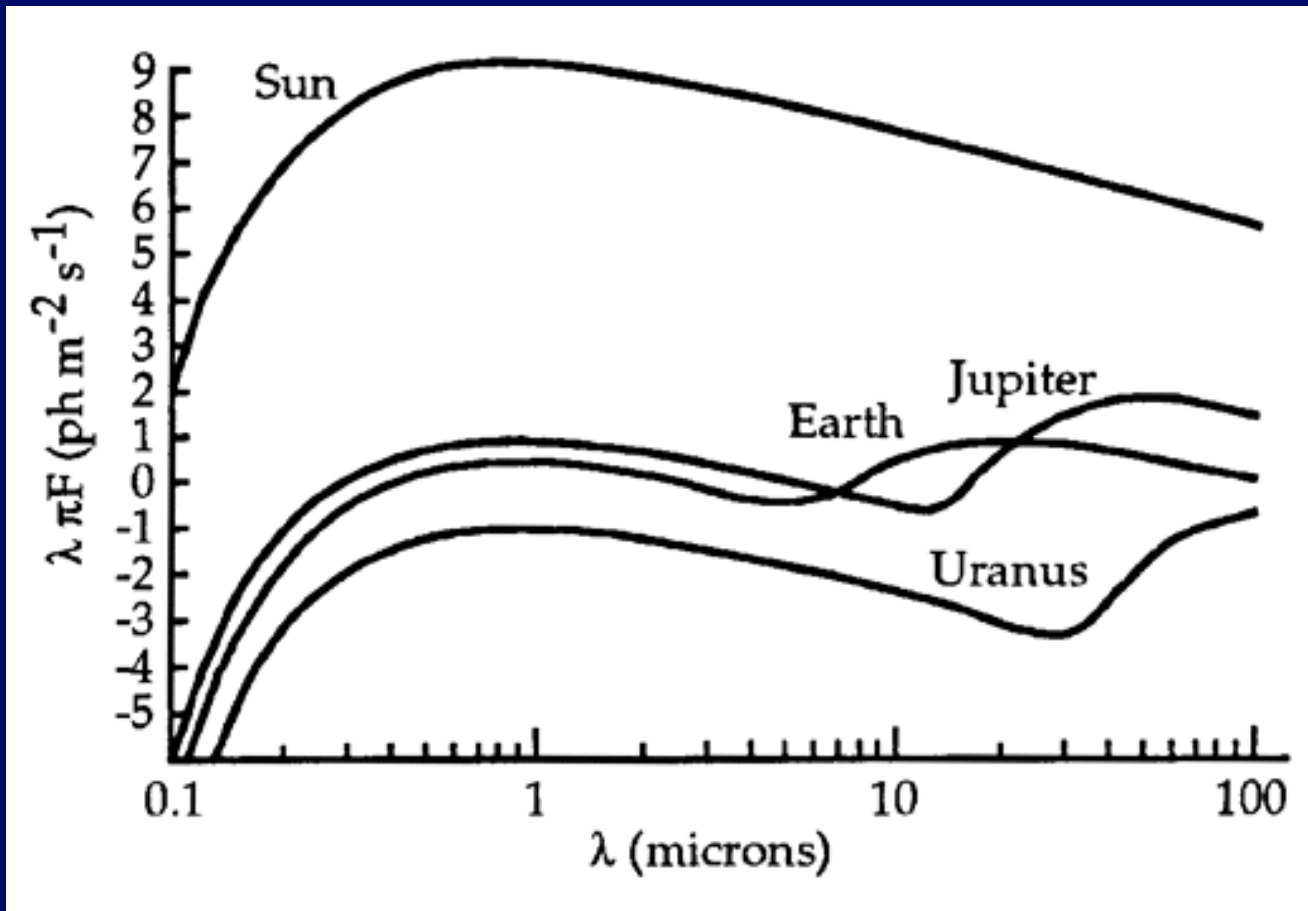

Indirect Detection

Wobbling star

Detect effect of planet on star (both orbit around center of mass)

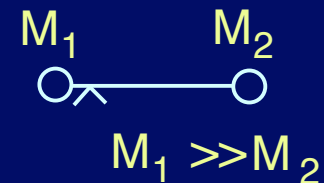
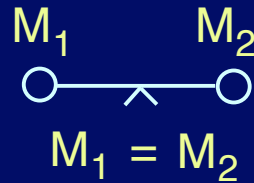

Large planet will make a star “wobble”

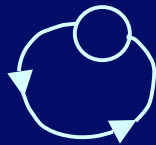

In plane of sky observe
position shift



Along our line of
sight

Observe Doppler
Shift

Star and Planet Orbit Center of Mass

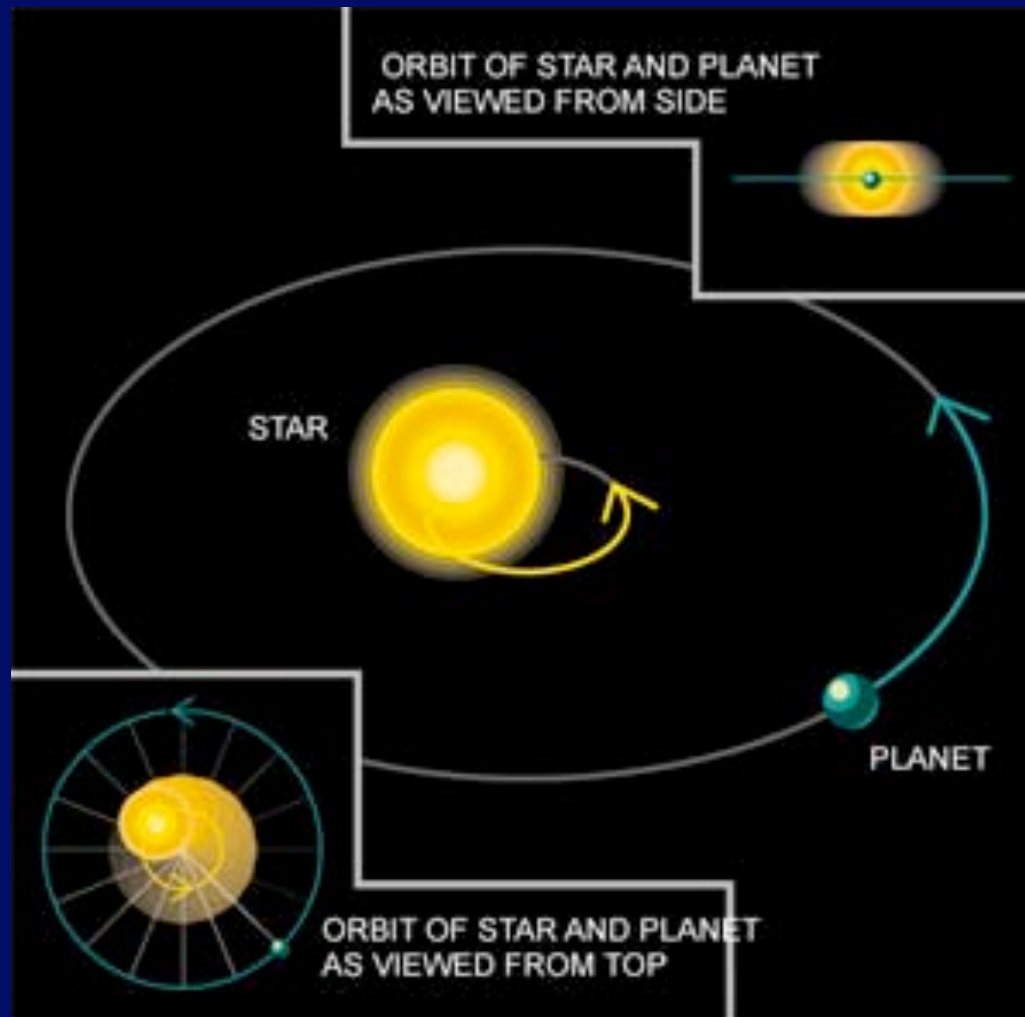

The Astrometric Technique

Measure stellar position (angle) accurately - see wobble compared to more distant stars

How far does the star wobble?

Center of mass

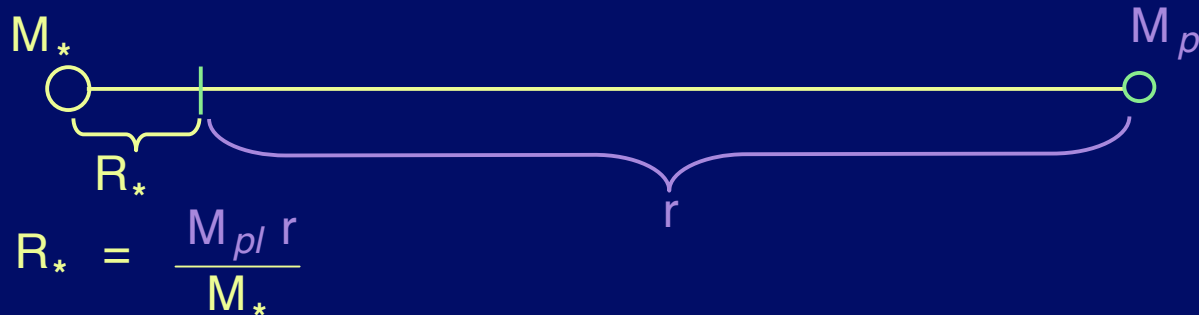

We measure angle; for small angles,

$$\Theta = \frac{R_*}{D} \quad \text{in radians}$$



so
$$\Theta = \frac{M_{pl} r}{M_*} \frac{1}{D}$$
 Big planet, big orbit
small star, close to sun

Current limit: 1 mas = 10^{-3} arcsec = 2.8×10^{-6} degrees
= 4.9×10^{-8} radians

e.g. $M_{pl} = M_{Jupiter}$, $M_* = M_{\odot}$, $D = 15 \text{ ly} \Rightarrow \Theta = 1 \text{ mas}$

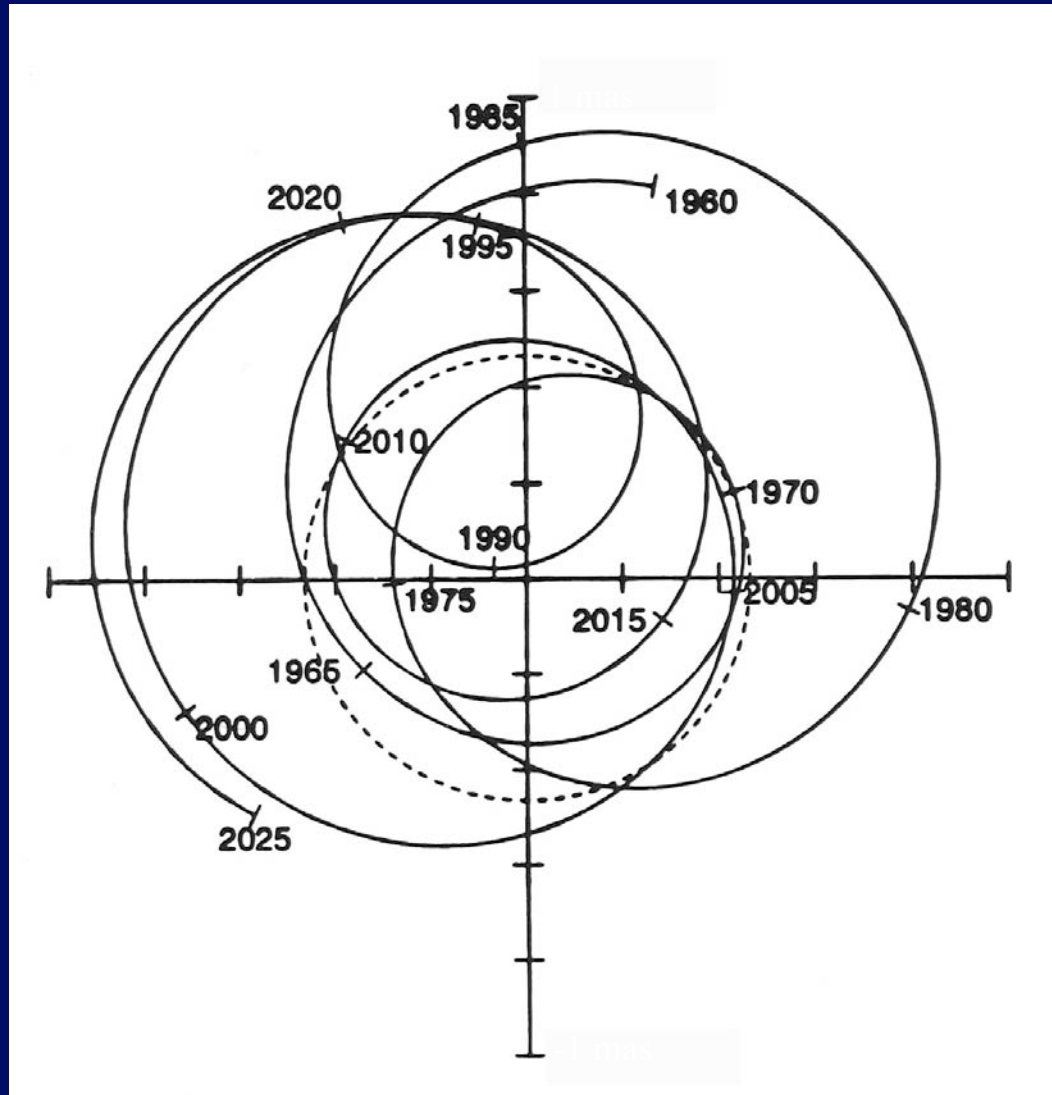

The Sun as viewed from 10 pc (~ 30 ly)

30 ly

Planet	M_p (M_J)	R (AU)	P (years)	V_\star ($m s^{-1}$)	Θ at 10 pc (mas)
Mercury	1.74E-4	0.387	0.241	0.008	6.4E-6
Venus	2.56E-3	0.723	0.615	0.086	1.8E-4
Earth	3.15E-3	1.000	1.000	0.089	3.0E-4
Mars	3.38E-4	1.524	1.881	0.008	4.9E-5
Jupiter	1.0	5.203	11.86	12.4	0.497
Saturn	0.299	9.54	29.46	2.75	0.273
Uranus	0.046	19.18	84.01	0.297	0.084
Neptune	0.054	30.06	164.8	0.281	0.156
Pluto	6.3E-6	39.44	247.7	3E-5	2.4E-5

The Spectroscopic Method

- Relies on Doppler Effect
- Motion of star towards and away from us
- Almost all planets around other stars found by this method so far

The Doppler Shift

Light is a wave

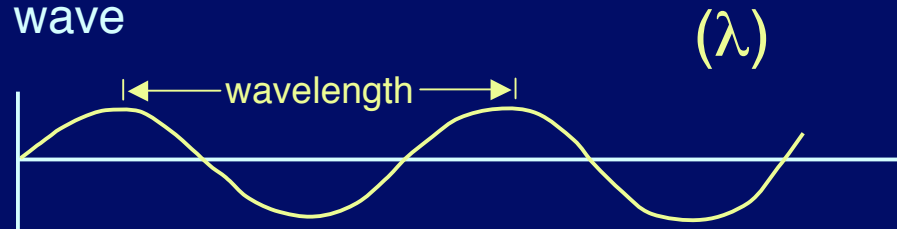

moving star

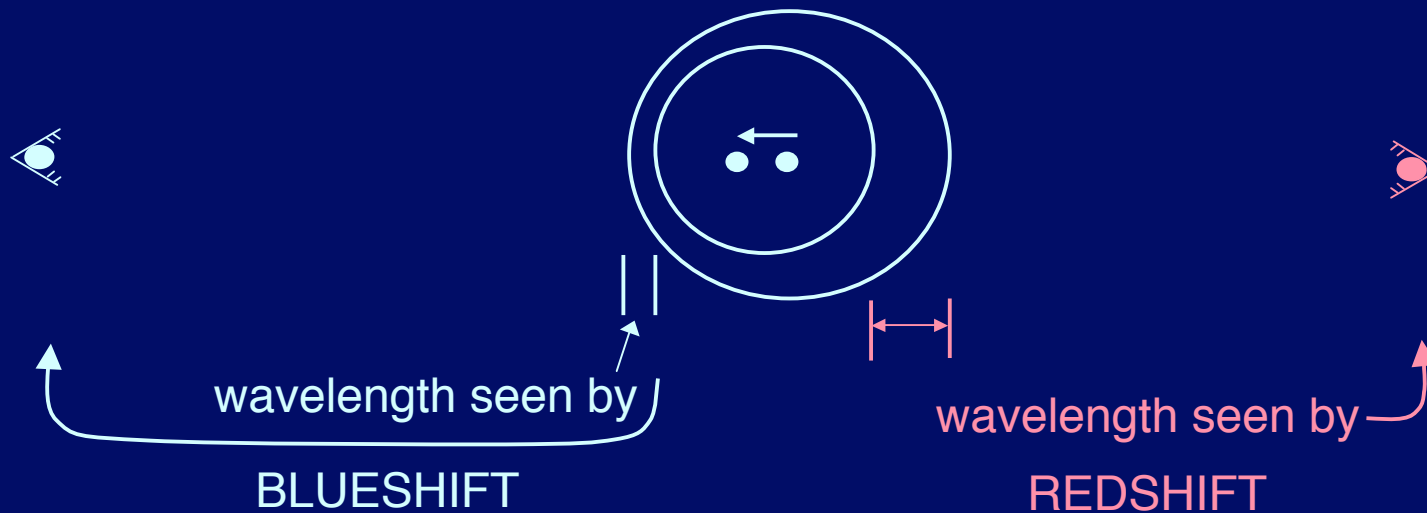

$$\frac{\lambda_{\text{observed}}}{\lambda_{\text{emitted}}} = 1 + \frac{v}{c}$$

Doppler Shift \longrightarrow Magnitude and direction of velocity

But only along line-of-sight

The Spectroscopic Technique

Measure velocity, not position, of star

Use spectrometer to get Doppler Shift of spectral line

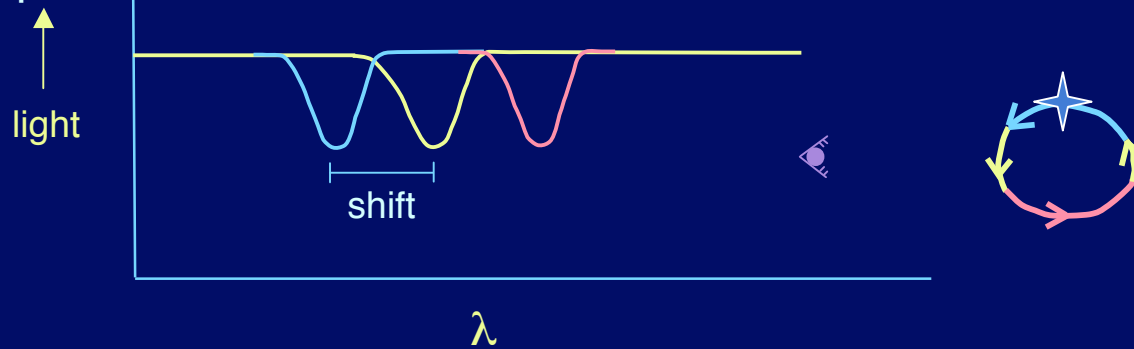

$$\text{Shift} \propto V_* \propto \frac{M_{pl}}{M_*^{1/2}} r^{1/2}$$

Big planet, small orbit

Small star

Distance doesn't matter (except for brightness)

Edge - On

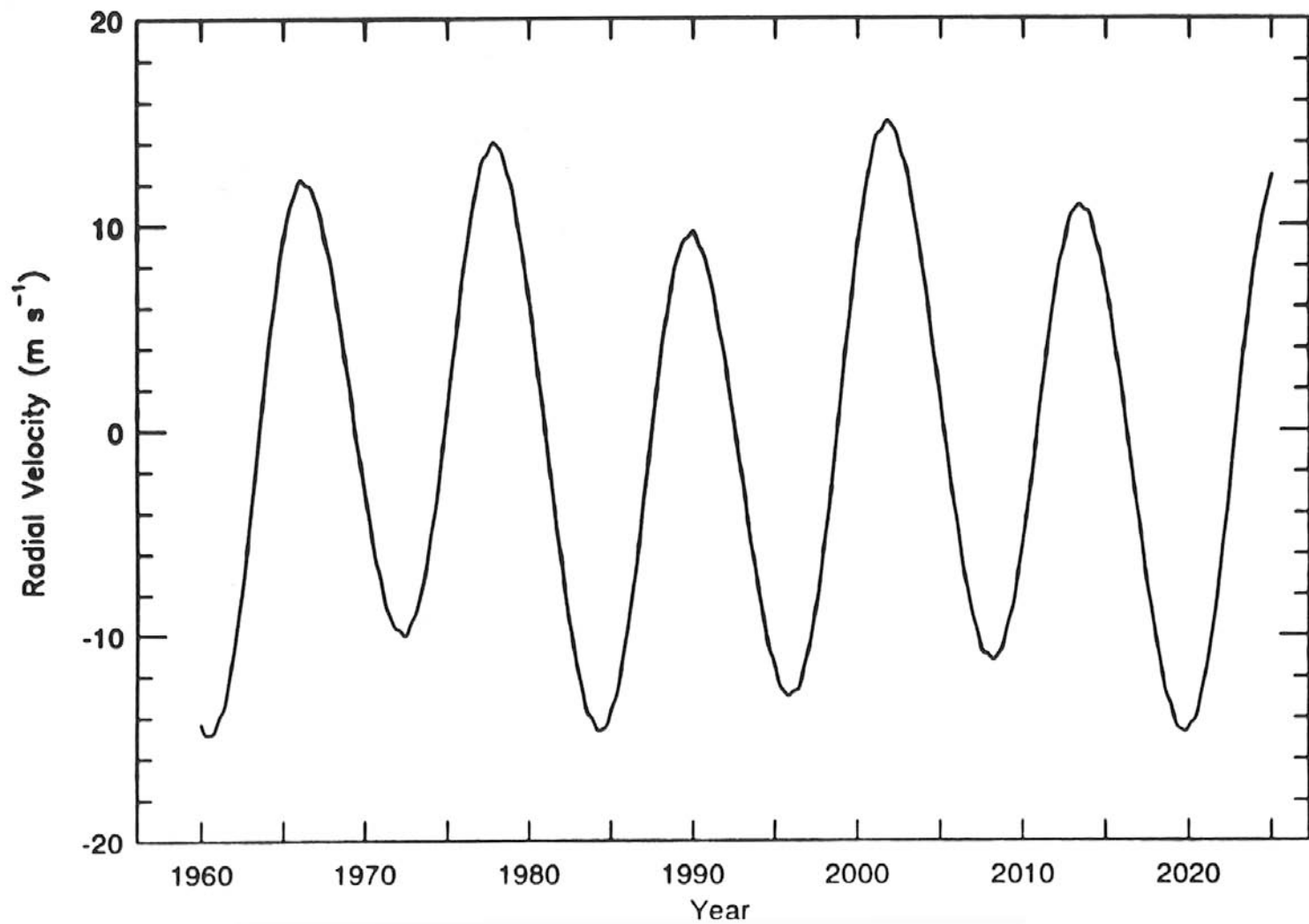

Motion of the Sun caused by Jupiter, ...

30 ly

Planet	M_p (M_J)	R (AU)	P (years)	V_\star ($m s^{-1}$)	Θ at 10 pc (mas)
Mercury	1.74E-4	0.387	0.241	0.008	6.4E-6
Venus	2.56E-3	0.723	0.615	0.086	1.8E-4
Earth	3.15E-3	1.000	1.000	0.089	3.0E-4
Mars	3.38E-4	1.524	1.881	0.008	4.9E-5
Jupiter	1.0	5.203	11.86	12.4	0.497
Saturn	0.299	9.54	29.46	2.75	0.273
Uranus	0.046	19.18	84.01	0.297	0.084
Neptune	0.054	30.06	164.8	0.281	0.156
Pluto	6.3E-6	39.44	247.7	3E-5	2.4E-5

What We Can Learn

1. There is a planet
(If not a mistake)
2. The orbital period (P)
(The time for pattern to repeat)

3. The orbital radius

$$r^3 \propto M_* P^2$$

(Kepler's Third Law)

4. Lower limit to planet mass (M_{planet})

Conservation of momentum \longrightarrow

$$M_{pl} \geq \frac{M_* V_* P}{2\pi r}$$

= if we see orbit edge-on

> if tilted

Comparison of Search Methods

Advantages

Astrometric

Big Planet

Big Orbit

Small Star

Nearby Star

Spectroscopic

Big Planet

Small Orbit

Small Star

--

Edge-on Orbit

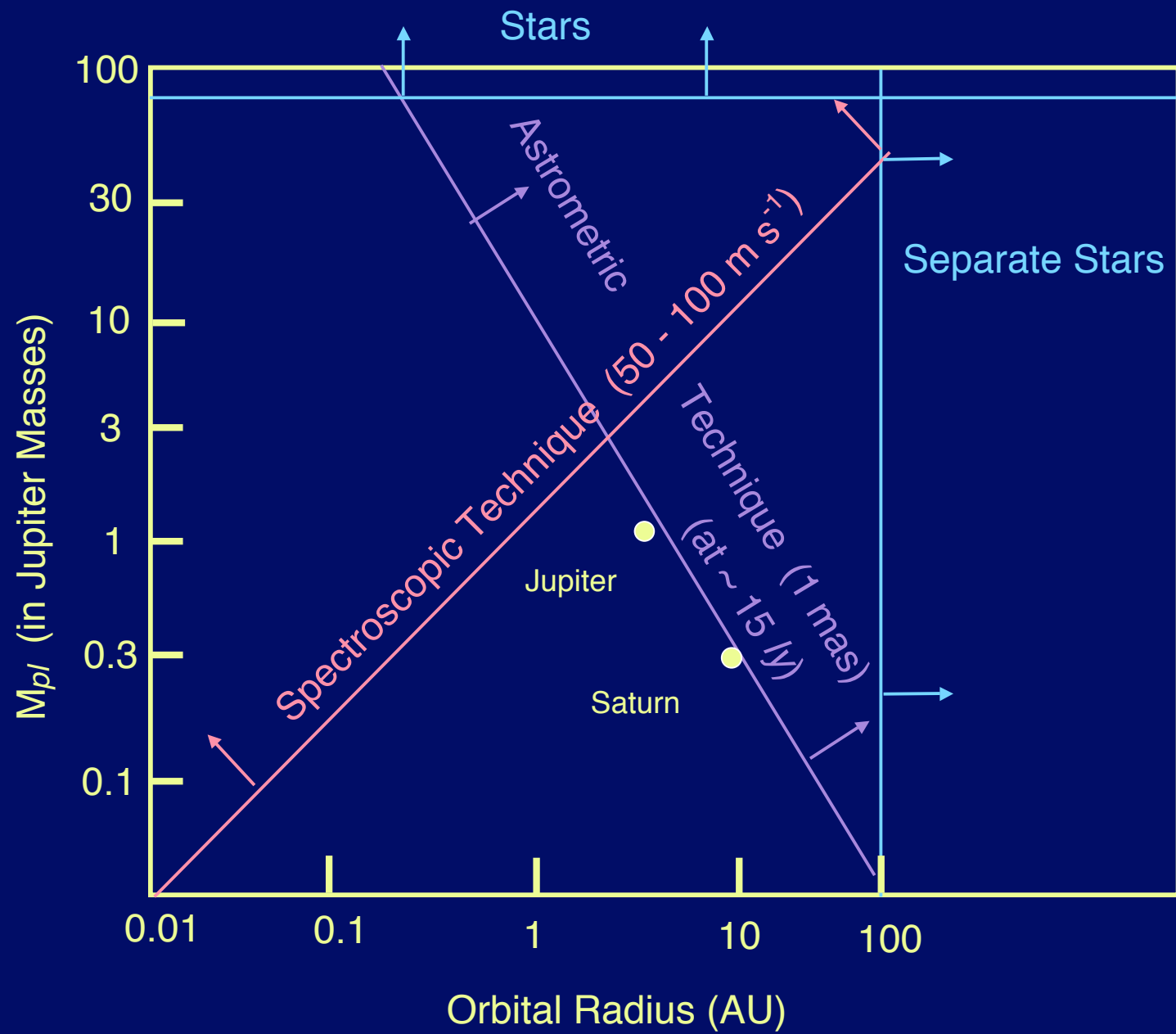

Other Methods

Transits: Planet passes in front of a star



US

Only about 0.5% of stars with planets will line up

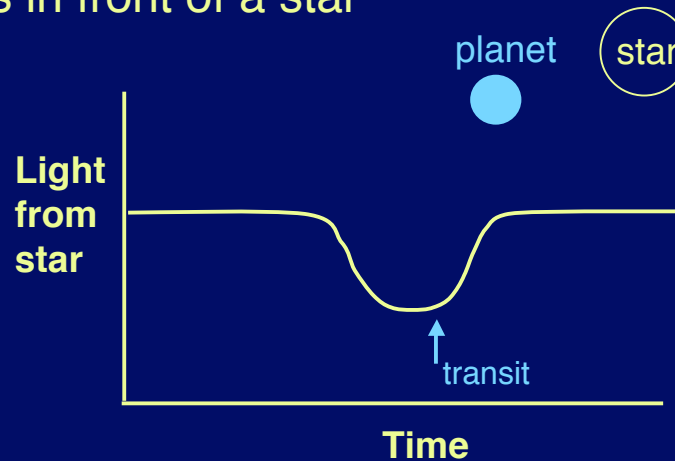

First planet found with this method in January 2003; 35 detected as of January 2008, 55 by January 2009

Microlensing: Light from more distant star is focused by gravity of nearer star passing in front



Fortuitous alignment \Rightarrow brightens

8 planets found this way as of January 2009

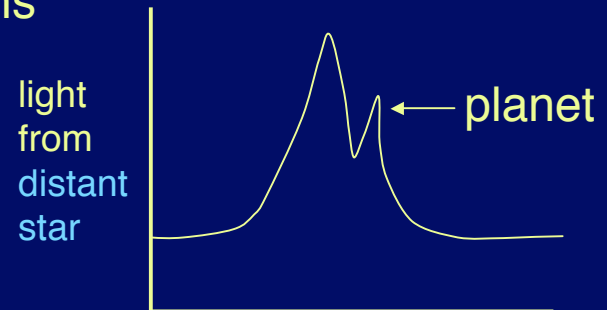

Artist's conception of Transit of HD209458

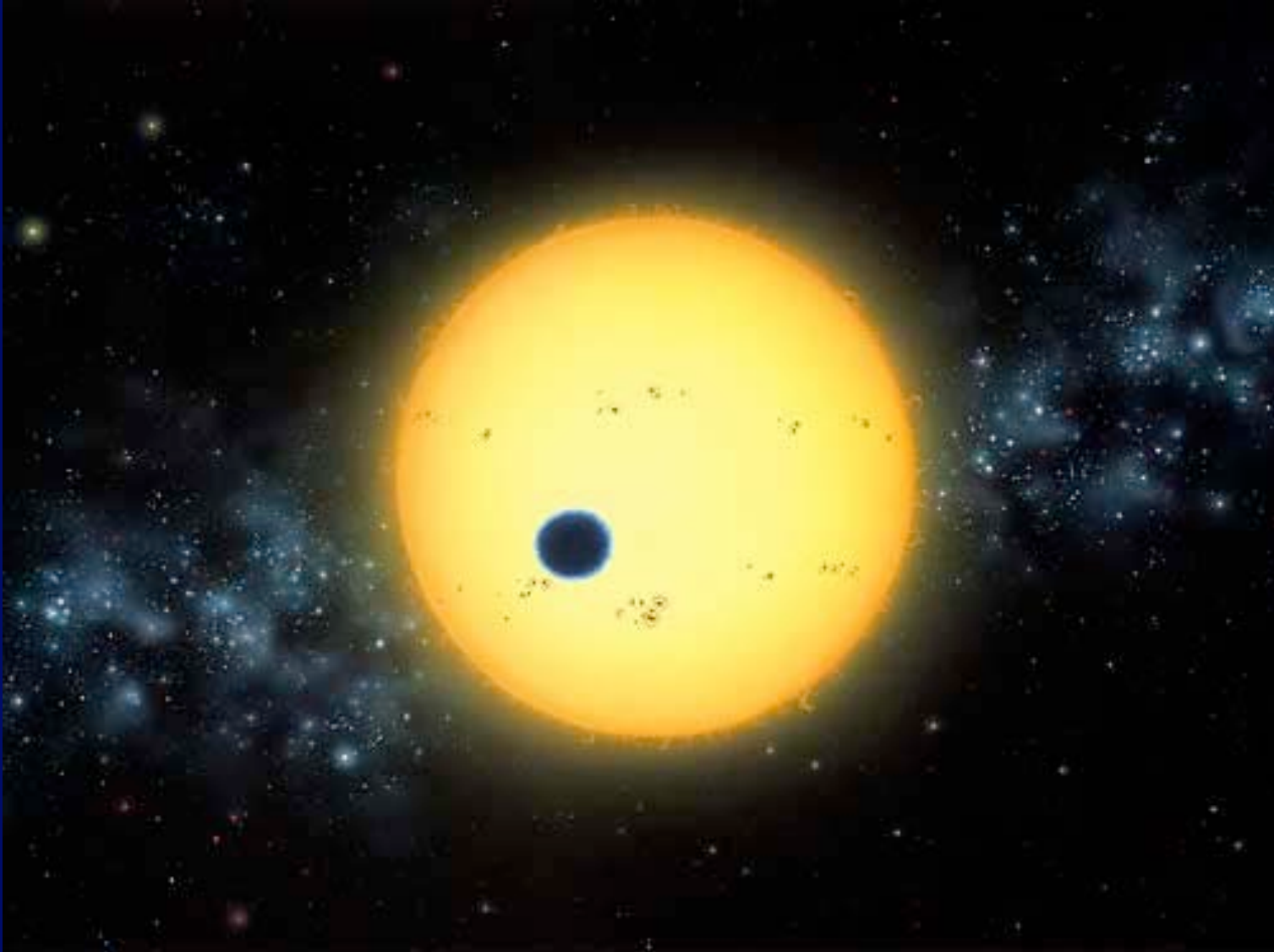

Copyright Lynette Cook
used with permission

<http://www.extrasolar.spaceart.org>

Timing

- Delays or advances in periodic signals
 - Pulses from pulsar
 - First planets found that way in 1992
 - Not suitable for life!
 - Oscillations in white dwarfs
 - First found this way in 2007 by grad student at UT

Planets from the Transit Method

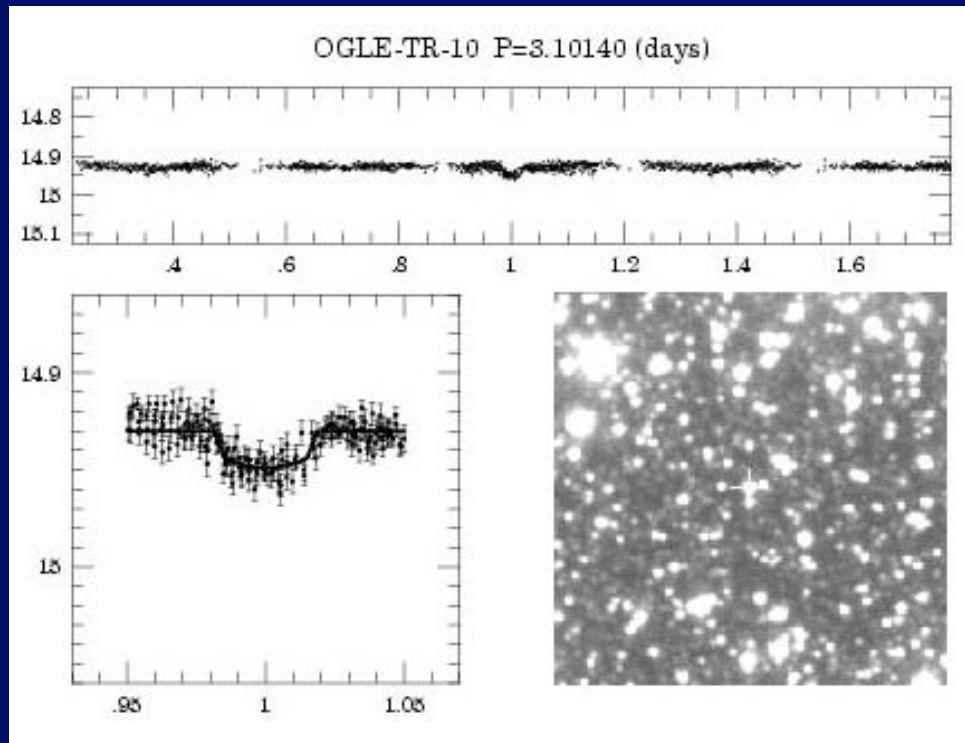

OGLE-TR-10

Light curve

Star field, shows star

Planet Detected by Microlensing

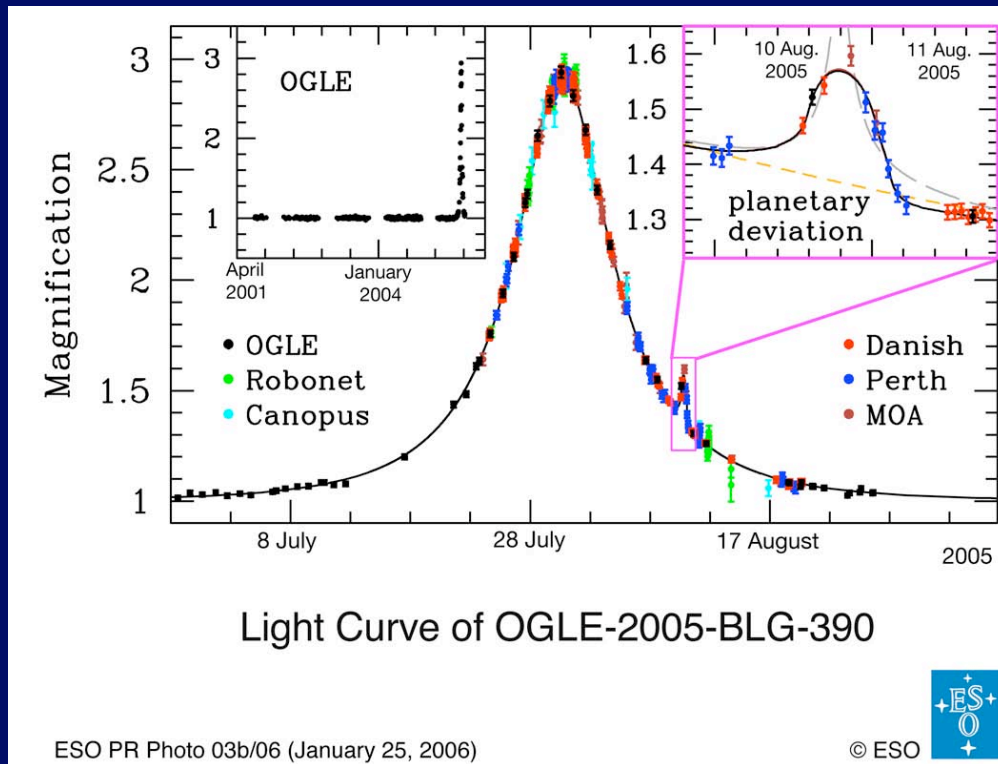

Sharp spike indicates second lens. Mass of second lens only 8×10^{-5} as massive as star. Most likely mass of planet is $5.5 M_{\text{earth}}$ and separation from star is 2.6 AU. Most likely star is low mass ($0.22 M_{\text{sun}}$).

This method can detect very low mass planets, but they are one-time events. Cannot follow up.

OGLE 2005-BLG-235Lb, announced 1/25/06

<http://www.eso.org/outreach/press-rel/pr-2006/pr-03-06.html>

Current Statistics (Jan. 2009)

- Based on Extrasolar Planets Encyclopedia
 - <http://exoplanet.eu/>
- 335 Planets
- 35 stars with multiple planets
- Most planets in one system is 5 (55 Cancri)
- Least massive
 - $M = 0.0132 M_{\text{Jup}} = 4.0 M_{\text{earth}}$ (HD40307b)

Implications of Planets around other stars

Planets more massive than Jupiter can form around stars like the Sun.

Large Planets can form much closer to a star than Jupiter (or move there)

Does this mean we are unusual and our ideas about other planetary systems are just “solar system chauvinism”?

Not necessarily.

The ones found so far are the “easy” ones. (Big planets close to a star)

Now there are many more with lower masses than higher masses.

Too early to say that we are unusual.

Number of planets for different masses

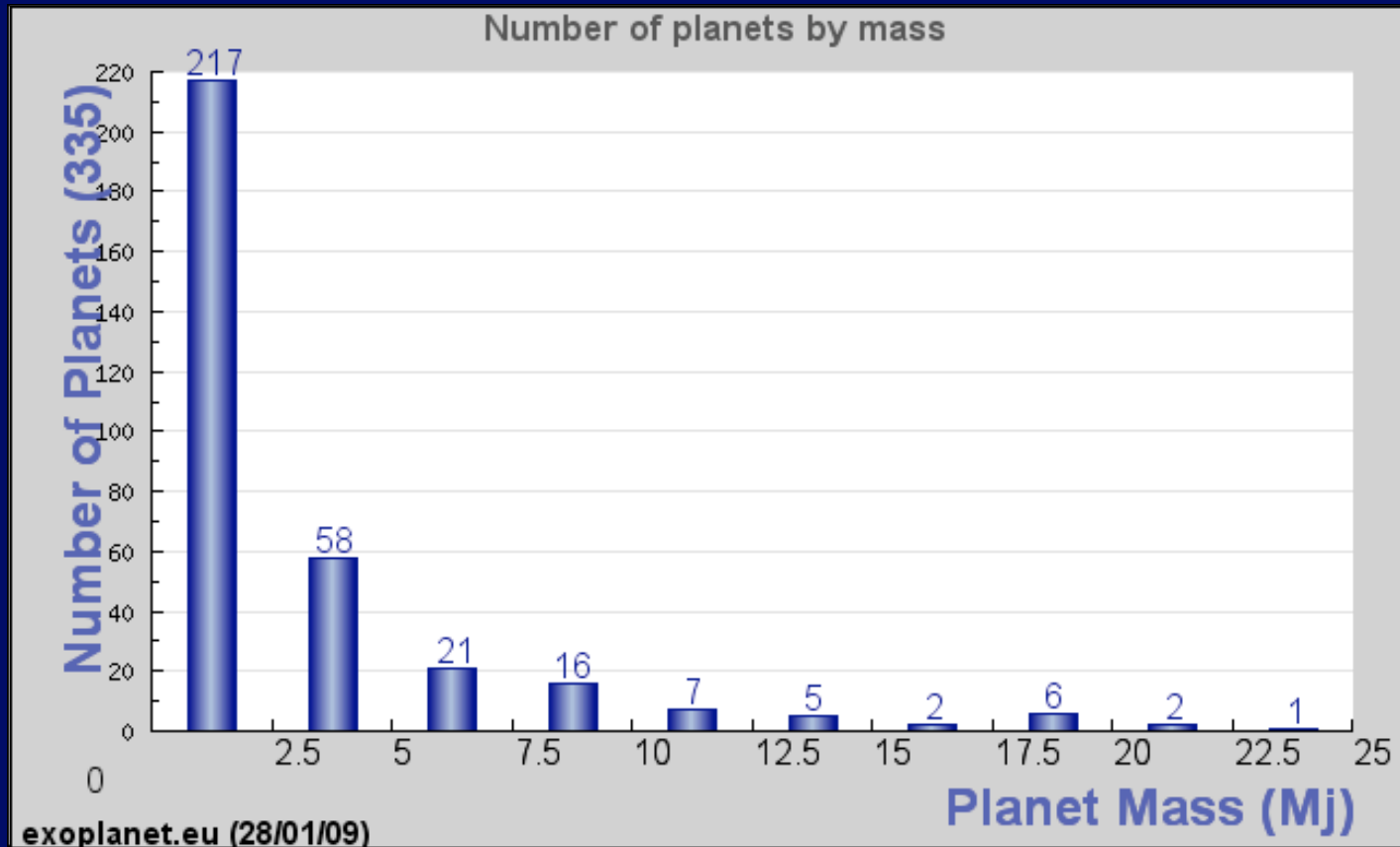

Estimating f_p

- Maximum? $f_p \sim 1$
 - All young stars may have disks
- Binaries?
 - Can have disks, but planet formation?
 - Even if form planets, orbits may not be stable
 - If reject binaries, $f_p < 0.3$

Estimating f_p

- Minimum?
 - Based on success rate of searches ($n_{\text{found}}/n_{\text{searched}}$)
 - Estimates now up to 15% ($f_p > 0.15$)
 - Note much larger than 0.02 given in book
 - Extrapolate trends to finding
 - Smaller planets, larger orbits, ...
 - Estimates range from 0.3 to 0.7
- Allowed range: $f_p = 0.15$ to 1.0
 - Explain your choice!
 - Include/exclude binaries?

The Upsilon Andromedae System

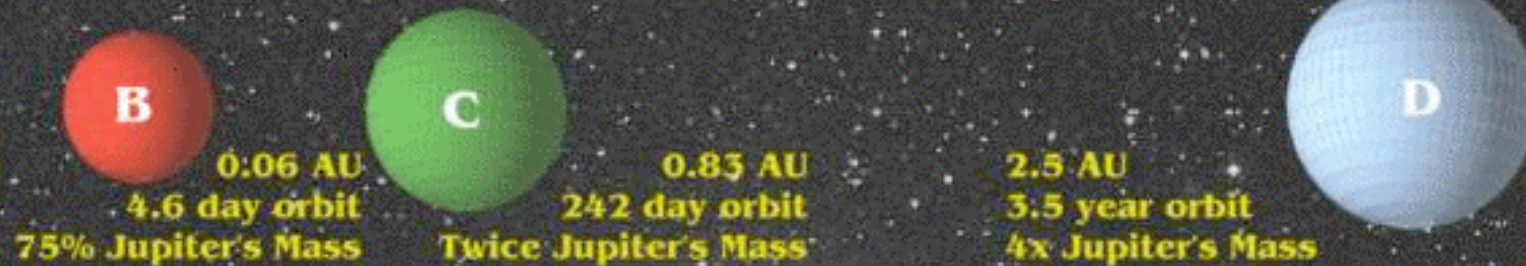

Our Inner Solar System

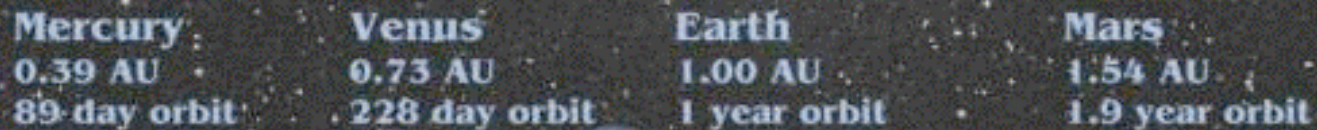

© Harvard-Smithsonian CFA (A. Condos), 1999

Future Prospects

Transits

CoRoT Dec. 2006-present

Has reported two planets as of Jan. 2008

Kepler (Launch scheduled for March 2009)

Monitor 100,000 stars for 4 years

“Hundreds of Terrestrial Planets”

Astrometric Method

GAIA ~ 2012

M_J Planets out to 600 ly.

Direct Detection NOW!

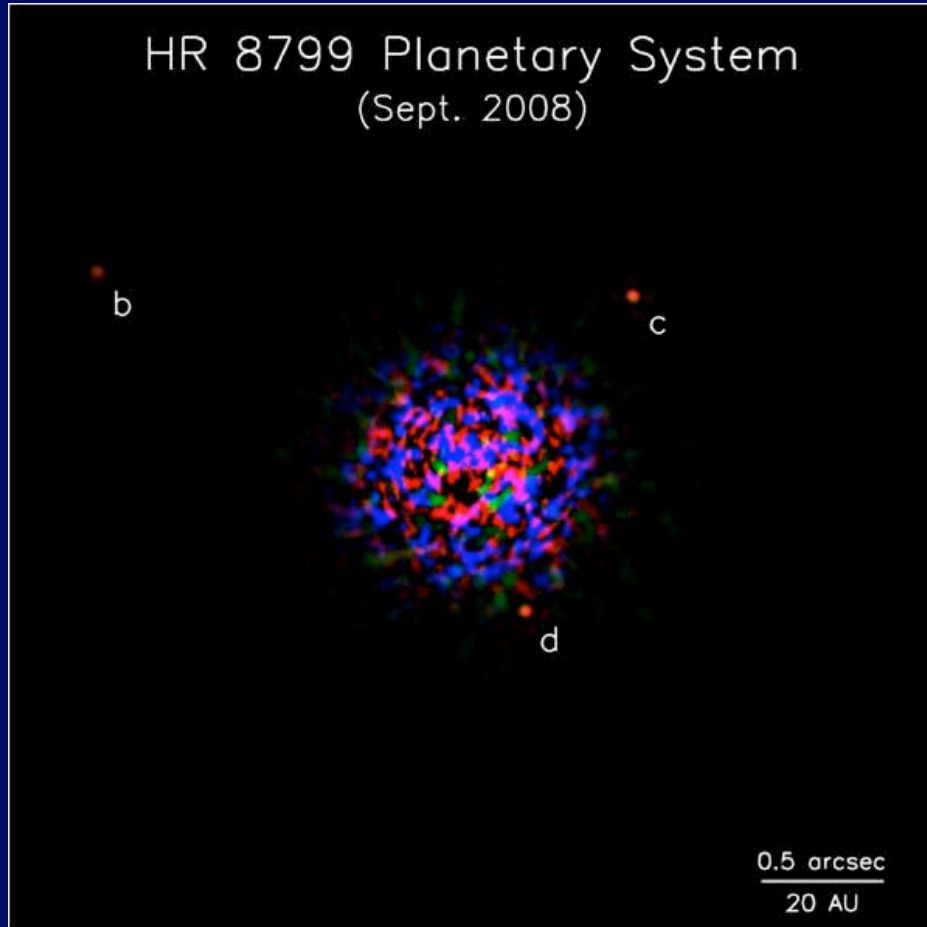

Three planets detected with ground-based telescopes working in the near-infrared. They used adaptive optics and other techniques to block the direct starlight and obtain very good spatial resolution.

Three planets at 24, 38, and 68 AU. Evidence for orbiting the star. Best guess masses 5-14 M_{jupiter} . Reported in Science, 2008, 322, 1348 by Marois et al.

And, in the same issue...

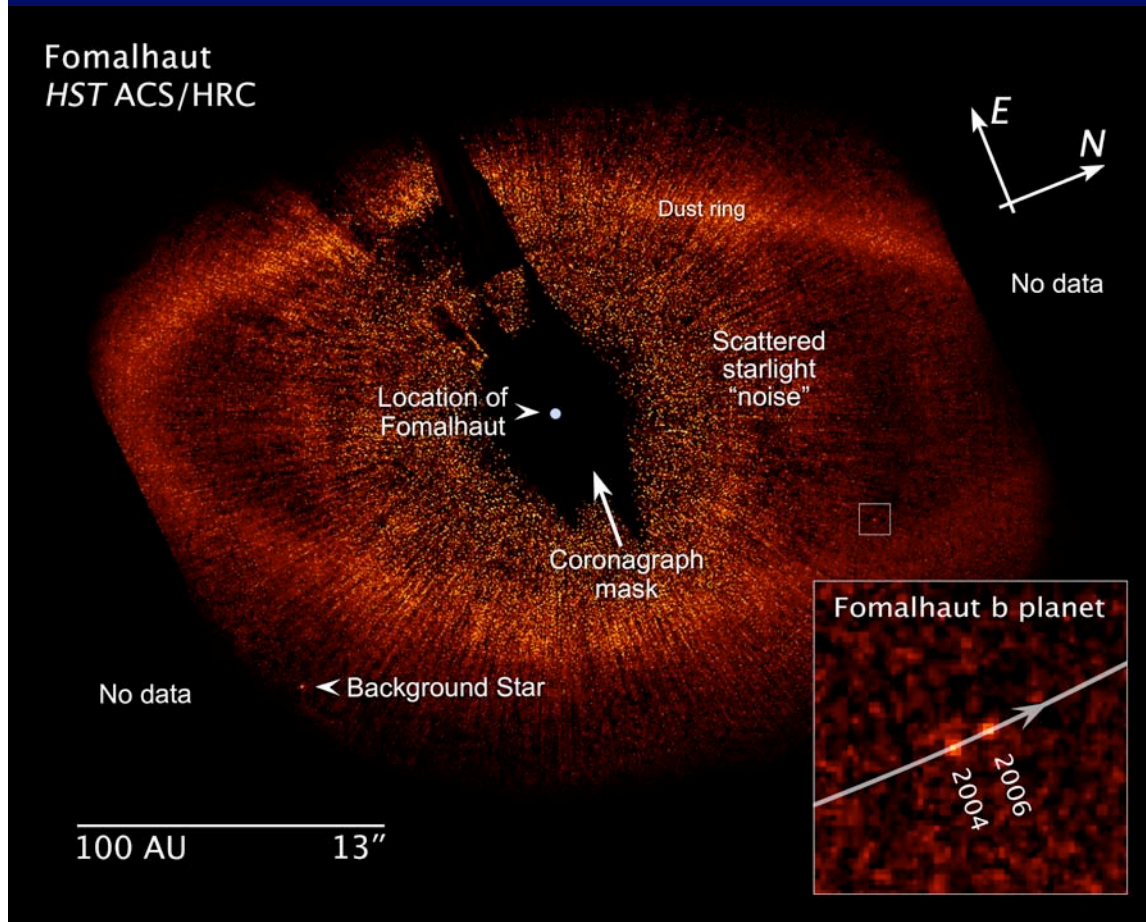

A planet just inside the dust ring around the star Fomalhaut. A coronagraph was used to block the star light and the Hubble Space Telescope avoids seeing. The faint spot in the box moves across the sky with Fomalhaut (proper motion), but with a slight shift due to its orbital motion (see inset). Announced by Kalas et al. *Science*, 2008, 322, 1345.

Planet about $3 M_{\text{jupiter}}$ and 119 AU from star. Keeps inner edge of dust ring sharp. Light may actually be reflected off a circumplanetary disk.

Direct Detection in Future

- Terrestrial Planet Finder (TPF)/Darwin
 - TPF-C Visible light coronagraph (~2014)
 - TPF-I Infrared interferometer (~2020)
- Goal is to detect earth-mass planets
- And to see what gases in atmosphere
 - Suitable for life?
- http://planetquest.jpl.nasa.gov/TPF/tpf_index.html

TPF Concepts

TPF-I Infrared Interferometer (2020)

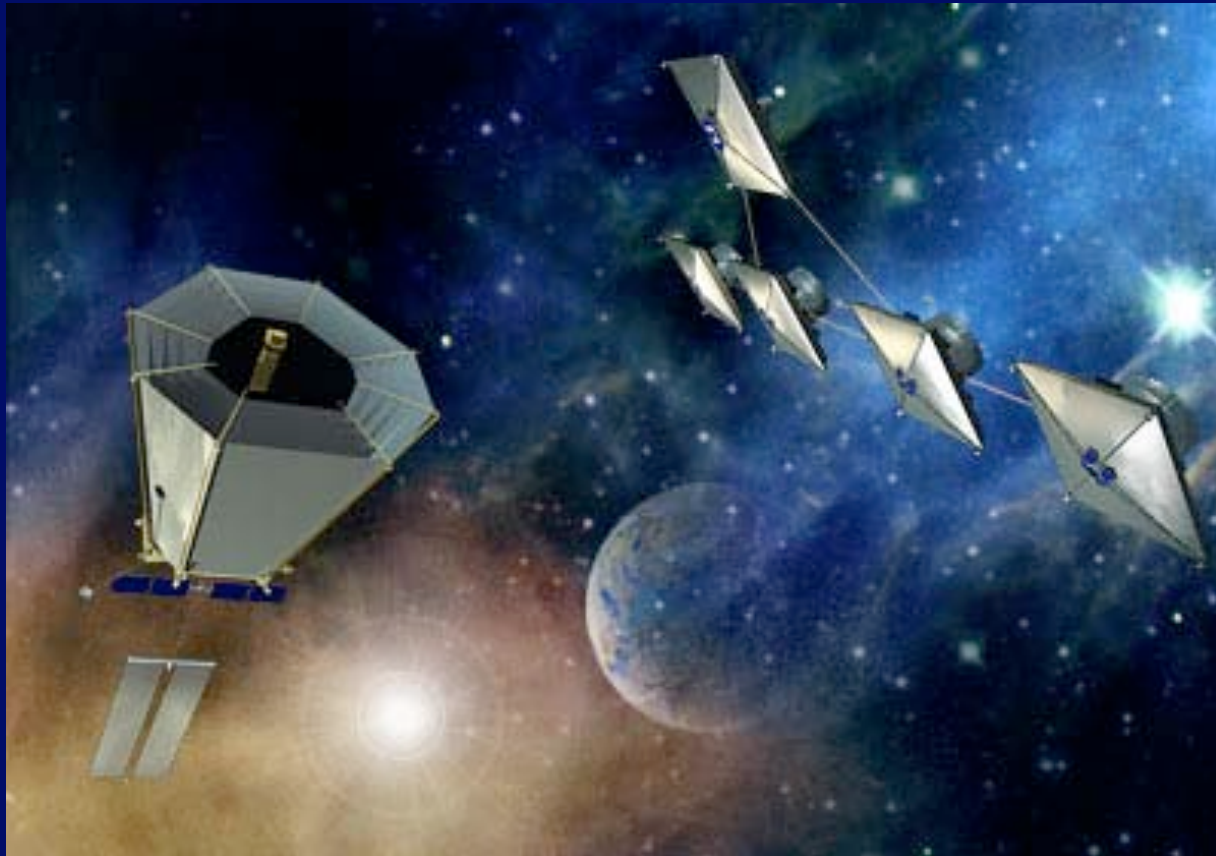

TPF-C Visible light coronagraph (2014)

Spectroscopy of atmosphere

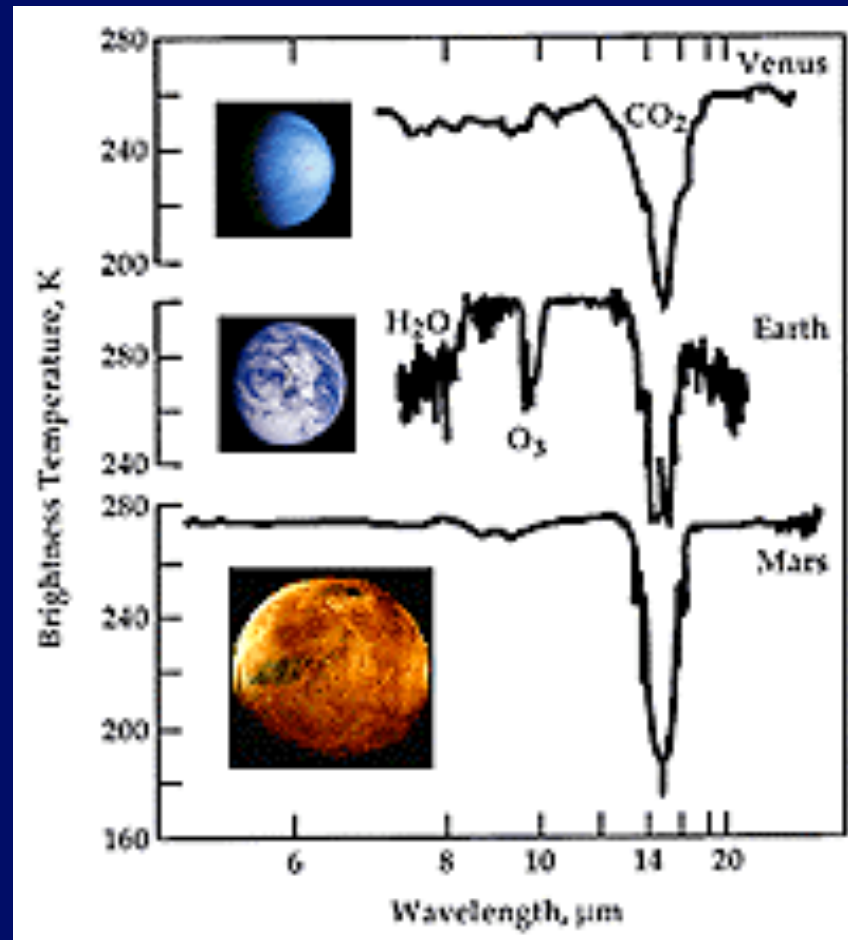

Planet Detection Methods

Michael Perryman, Rep. Prog. Phys., 2000, 63, 1209 (updated November 2004)

[corrections or suggestions please to michael.perryman@esa.int]

